

Alliant Engineering

Minneapolis, MN 55415

--TRAFFIC DATA --

TH-110 at TH-13
 Ref.Pt.; 000.390
 data by Alliant Engineering
 TURN MOVEMENT COUNT

File Name : 411 - TH 110 and TH 13
 Site Code : 411
 Start Date : 4/9/2015
 Page No : 1

Groups Printed- Cars - Trucks

Start Time	TH-13 Southbound				TH-110 Westbound				TH-13 Northbound				TH-110 Eastbound				Int. Total
	Left	Thru	Rght	Bikes	Left	Thru	Rght	Bikes	Left	Thru	Rght	Bikes	Left	Thru	Rght	Bikes	
06:00	0	1	6	0	13	134	0	0	1	0	5	0	1	35	1	0	197
06:15	0	2	6	0	7	192	2	0	4	4	8	0	3	45	2	0	275
06:30	0	3	9	0	15	276	0	0	3	0	10	0	3	75	3	0	397
06:45	1	1	6	0	11	357	2	0	6	2	6	0	5	100	6	0	503
Total	1	7	27	0	46	959	4	0	14	6	29	0	12	255	12	0	1372
07:00	1	7	13	0	13	359	0	0	4	2	3	0	20	95	5	0	522
07:15	0	1	9	0	12	423	1	0	6	6	7	0	5	82	2	0	554
07:30	1	6	11	0	12	421	1	0	3	7	19	0	4	183	21	0	689
07:45	3	10	25	0	16	370	3	0	5	9	16	0	5	143	10	0	615
Total	5	24	58	0	53	1573	5	0	18	24	45	0	34	503	38	0	2380
08:00	1	3	21	0	16	312	3	0	3	14	6	0	17	172	3	0	571
08:15	0	6	9	0	10	301	2	0	7	15	22	0	8	129	9	0	518
08:30	1	10	14	0	17	278	2	0	3	6	10	0	7	148	8	0	504
08:45	1	6	16	0	13	249	6	0	4	16	15	0	5	137	8	1	477
Total	3	25	60	0	56	1140	13	0	17	51	53	0	37	586	28	1	2070
09:00	1	5	13	0	12	183	11	0	4	5	10	0	4	126	12	0	386
09:15	1	3	9	0	13	187	1	1	6	3	5	0	3	117	8	0	357
*** BREAK ***																	
Total	2	8	22	0	25	370	12	1	10	8	15	0	7	243	20	0	743
*** BREAK ***																	
10:30	2	2	11	0	1	136	4	0	3	3	17	0	5	124	5	0	313
10:45	2	7	4	0	10	140	4	0	8	4	11	0	11	98	4	0	303
Total	4	9	15	0	11	276	8	0	11	7	28	0	16	222	9	0	616
11:00	3	5	5	0	12	119	9	0	5	7	13	0	13	122	5	0	318
11:15	1	2	5	0	6	123	5	2	7	16	16	0	6	122	9	0	320
11:30	1	6	9	0	11	123	4	0	4	6	21	0	20	115	4	0	324
11:45	5	6	8	0	18	165	4	0	4	12	10	0	8	162	4	0	406
Total	10	19	27	0	47	530	22	2	20	41	60	0	47	521	22	0	1368
12:00	2	11	9	0	11	115	4	0	8	26	23	0	9	116	4	0	338
12:15	5	2	5	0	7	139	7	0	5	7	14	0	4	140	3	0	338
12:30	6	13	7	0	19	154	4	0	5	10	15	0	11	134	1	0	379
12:45	4	11	6	0	13	132	4	0	8	8	15	0	7	145	4	0	357
Total	17	37	27	0	50	540	19	0	26	51	67	0	31	535	12	0	1412
13:00	5	14	10	0	12	113	4	1	1	8	9	0	10	141	3	0	331
13:15	4	6	10	0	13	106	1	0	4	6	8	0	4	133	2	0	297
13:30	0	0	0	0	11	126	2	0	6	15	30	0	0	0	0	0	190
*** BREAK ***																	
Total	9	20	20	0	36	345	7	1	11	29	47	0	14	274	5	0	818
*** BREAK ***																	
14:30	6	3	5	0	6	137	5	0	5	9	42	0	9	170	7	0	404
14:45	7	11	10	0	10	131	4	0	4	2	27	0	14	239	6	0	465
Total	13	14	15	0	16	268	9	0	9	11	69	0	23	409	13	0	869
15:00	4	6	14	0	6	141	2	0	7	8	15	0	9	225	4	0	441
15:15	1	5	10	0	10	149	6	0	8	4	16	0	7	259	8	0	483
15:30	3	4	12	0	12	143	5	0	13	14	36	0	25	254	2	0	523
15:45	4	6	12	0	9	181	11	0	5	14	17	0	14	308	3	0	584
Total	12	21	48	0	37	614	24	0	33	40	84	0	55	1046	17	0	2031
16:00	2	8	16	0	4	147	3	0	11	13	25	0	21	295	2	0	547
16:15	4	12	10	0	10	169	2	0	14	14	21	0	18	359	4	0	637

Alliant Engineering

Minneapolis, MN 55415

--TRAFFIC DATA --

TH-110 at TH-13
 Ref.Pt.; 000.390
 data by Alliant Engineering
 TURN MOVEMENT COUNT

File Name : 411 - TH 110 and TH 13
 Site Code : 411
 Start Date : 4/9/2015
 Page No : 2

Groups Printed- Cars - Trucks

Start Time	TH-13 Southbound				TH-110 Westbound				TH-13 Northbound				TH-110 Eastbound				Int. Total
	Left	Thru	Rght	Bikes	Left	Thru	Rght	Bikes	Left	Thru	Rght	Bikes	Left	Thru	Rght	Bikes	
16:30	5	11	8	0	9	174	11	0	19	9	25	0	22	353	8	0	654
16:45	2	14	11	0	11	182	11	0	18	13	27	0	28	380	6	0	703
Total	13	45	45	0	34	672	27	0	62	49	98	0	89	1387	20	0	2541
17:00	3	12	11	0	5	163	10	0	18	22	26	0	31	337	6	0	644
17:15	4	10	14	0	9	175	13	0	15	15	24	0	25	366	7	0	677
17:30	7	17	14	0	8	177	13	0	14	17	25	0	20	297	3	0	612
17:45	4	9	12	0	10	193	6	0	8	14	26	0	30	297	3	0	612
Total	18	48	51	0	32	708	42	0	55	68	101	0	106	1297	19	0	2545
*** BREAK ***																	
Grand Total	107	277	415	0	443	7995	192	4	286	385	696	0	471	7278	215	1	18765
Apprch %	13.4	34.7	51.9	0	5.1	92.6	2.2	0	20.9	28.2	50.9	0	5.9	91.4	2.7	0	
Total %	0.6	1.5	2.2	0	2.4	42.6	1	0	1.5	2.1	3.7	0	2.5	38.8	1.1	0	
Cars	103	272	408	0	427	7897	191	2	283	373	675	0	463	7200	213	1	18508
% Cars	96.3	98.2	98.3	0	96.4	98.8	99.5	50	99	96.9	97	0	98.3	98.9	99.1	100	98.6
Trucks	4	5	7	0	16	98	1	2	3	12	21	0	8	78	2	0	257
% Trucks	3.7	1.8	1.7	0	3.6	1.2	0.5	50	1	3.1	3	0	1.7	1.1	0.9	0	1.4

Alliant Engineering

Minneapolis, MN 55415

--TRAFFIC DATA --

TH-110 at TH-13
 Ref.Pt.; 000.390
 data by Alliant Engineering
 TURN MOVEMENT COUNT

File Name : 411 - TH 110 and TH 13
 Site Code : 411
 Start Date : 4/9/2015
 Page No : 3

Start Time	TH-13 Southbound					TH-110 Westbound					TH-13 Northbound					TH-110 Eastbound					Int. Total
	Left	Thru	Rght	Bikes	App. Total	Left	Thru	Rght	Bikes	App. Total	Left	Thru	Rght	Bikes	App. Total	Left	Thru	Rght	Bikes	App. Total	
Peak Hour Analysis From 06:00 to 11:45 - Peak 1 of 1																					
Peak Hour for Entire Intersection Begins at 07:15																					
07:15	0	1	9	0	10	12	423	1	0	436	6	6	7	0	19	5	82	2	0	89	554
07:30	1	6	11	0	18	12	421	1	0	434	3	7	19	0	29	4	183	21	0	208	689
07:45	3	10	25	0	38	16	370	3	0	389	5	9	16	0	30	5	143	10	0	158	615
08:00	1	3	21	0	25	16	312	3	0	331	3	14	6	0	23	17	172	3	0	192	571
Total Volume	5	20	66	0	91	56	1526	8	0	1590	17	36	48	0	101	31	580	36	0	647	2429
% App. Total	5.5	22	72.5	0		3.5	96	0.5	0		16.8	35.6	47.5	0		4.8	89.6	5.6	0		
PHF	.417	.500	.660	.000	.599	.875	.902	.667	.000	.912	.708	.643	.632	.000	.842	.456	.792	.429	.000	.778	.881

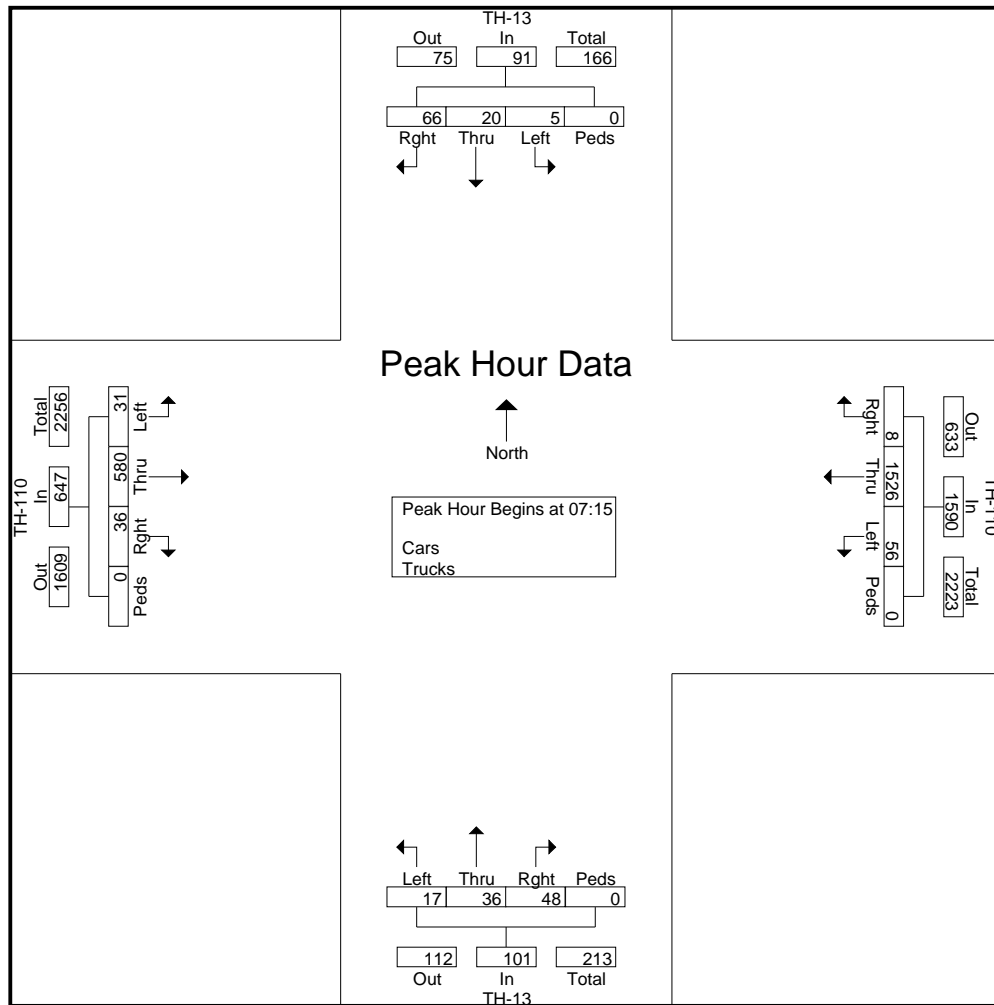

Alliant Engineering

Minneapolis, MN 55415

--TRAFFIC DATA --

TH-110 at TH-13
 Ref.Pt.; 000.390
 data by Alliant Engineering
 TURN MOVEMENT COUNT

File Name : 411 - TH 110 and TH 13
 Site Code : 411
 Start Date : 4/9/2015
 Page No : 4

Start Time	TH-13 Southbound					TH-110 Westbound					TH-13 Northbound					TH-110 Eastbound					Int. Total
	Left	Thru	Rght	Bikes	App. Total	Left	Thru	Rght	Bikes	App. Total	Left	Thru	Rght	Bikes	App. Total	Left	Thru	Rght	Bikes	App. Total	
Peak Hour Analysis From 12:00 to 18:00 - Peak 1 of 1																					
Peak Hour for Entire Intersection Begins at 16:30																					
16:30	5	11	8	0	24	9	174	11	0	194	19	9	25	0	53	22	353	8	0	383	654
16:45	2	14	11	0	27	11	182	11	0	204	18	13	27	0	58	28	380	6	0	414	703
17:00	3	12	11	0	26	5	163	10	0	178	18	22	26	0	66	31	337	6	0	374	644
17:15	4	10	14	0	28	9	175	13	0	197	15	15	24	0	54	25	366	7	0	398	677
Total Volume	14	47	44	0	105	34	694	45	0	773	70	59	102	0	231	106	1436	27	0	1569	2678
% App. Total	13.3	44.8	41.9	0		4.4	89.8	5.8	0		30.3	25.5	44.2	0		6.8	91.5	1.7	0		
PHF	.700	.839	.786	.000	.938	.773	.953	.865	.000	.947	.921	.670	.944	.000	.875	.855	.945	.844	.000	.947	.952

