



MINNESOTA DEPT OF TRANSPORTATION

TRAFFIC DATA COLLECTION - METRO

Location : TH-65 AT 44TH AVE NE
 Ref.Pt.: 005.011
 JAMAR# 632 DR
 TURN MOVEMENT COUNT

File Name : TH-65 AT 44TH AVE NE 2009
 Site Code : 00000000
 Start Date : 4/15/2009
 Page No : 1

Groups Printed- Unshifted

Start Time	TH 65 Southbound				44TH AVE NE Westbound				TH 65 Northbound				44TH AVE NE Eastbound				Int. Total
	Left	Thru	Right	Peds	Left	Thru	Right	Peds	Left	Thru	Right	Peds	Left	Thru	Right	Peds	
06:00	4	93	5	0	4	4	7	0	1	44	7	0	1	6	3	0	179
06:15	9	113	7	0	9	7	11	0	2	51	2	0	3	9	10	0	233
06:30	9	150	16	0	7	8	30	0	7	63	4	0	8	7	6	0	315
06:45	13	157	13	0	8	15	14	0	5	65	2	0	8	9	12	0	321
Total	35	513	41	0	28	34	62	0	15	223	15	0	20	31	31	0	1048
07:00	7	143	12	0	8	9	24	0	11	84	9	0	17	6	14	0	344
07:15	18	219	11	0	14	15	17	0	7	77	3	0	12	11	10	0	414
07:30	16	224	13	0	8	18	26	0	12	116	6	0	20	22	14	0	495
07:45	15	310	26	0	8	13	31	0	8	124	8	0	22	9	12	0	586
Total	56	896	62	0	38	55	98	0	38	401	26	0	71	48	50	0	1839
08:00	14	186	19	0	8	20	19	0	6	112	10	0	22	12	16	0	444
08:15	17	166	13	0	7	15	31	0	7	91	12	0	9	5	6	0	379
08:30	19	124	10	0	17	11	22	0	4	104	7	0	15	12	14	0	359
08:45	18	165	14	0	11	9	32	0	4	131	13	0	15	15	15	0	442
Total	68	641	56	0	43	55	104	0	21	438	42	0	61	44	51	0	1624
*** BREAK ***																	
11:00	25	146	17	0	21	23	37	0	5	148	11	0	17	23	19	0	492
11:15	19	134	19	0	16	23	39	0	10	150	15	0	12	27	21	0	485
11:30	20	187	23	0	14	21	36	0	11	165	18	0	25	26	13	0	559
11:45	28	137	27	1	12	21	33	0	21	176	15	0	33	34	22	0	560
Total	92	604	86	1	63	88	145	0	47	639	59	0	87	110	75	0	2096
12:00	27	184	30	0	7	12	44	0	9	208	20	0	23	32	20	0	616
12:15	36	174	24	0	12	24	46	0	25	191	20	0	33	24	11	0	620
12:30	24	187	26	0	14	22	33	0	17	193	9	0	31	26	18	0	600
12:45	26	173	33	0	16	22	47	0	17	173	12	0	25	16	16	0	576
Total	113	718	113	0	49	80	170	0	68	765	61	0	112	98	65	0	2412
*** BREAK ***																	
15:00	16	199	29	0	12	19	22	0	16	215	14	0	28	40	18	0	628
15:15	24	179	23	0	11	22	39	0	24	236	6	0	37	34	15	0	650
15:30	33	183	29	0	12	22	32	0	10	234	12	0	20	49	11	0	647
15:45	23	181	30	0	5	24	44	1	25	259	11	0	35	48	18	0	704
Total	96	742	111	0	40	87	137	1	75	944	43	0	120	171	62	0	2629
16:00	24	186	27	0	11	41	45	0	20	219	13	0	35	34	22	0	677
16:15	28	195	24	0	18	31	34	0	12	270	11	0	22	24	17	0	686
16:30	20	188	28	0	15	36	44	0	27	250	16	0	54	76	17	0	771
16:45	30	181	20	0	12	35	36	0	33	300	8	0	32	36	12	0	735
Total	102	750	99	0	56	143	159	0	92	1039	48	0	143	170	68	0	2869
17:00	24	160	31	0	2	23	35	0	30	263	7	0	31	38	17	0	661
17:15	17	174	14	0	9	25	26	0	22	295	13	0	33	26	14	0	668
17:30	18	157	23	0	5	19	29	0	18	229	4	0	23	24	18	0	567
17:45	10	186	24	0	15	33	13	0	13	227	10	0	41	34	25	0	631
Total	69	677	92	0	31	100	103	0	83	1014	34	0	128	122	74	0	2527
Grand Total	631	5541	660	1	348	642	978	1	439	5463	328	0	742	794	476	0	17044
Apprch %	9.2	81.1	9.7	0	17.7	32.6	49.7	0.1	7	87.7	5.3	0	36.9	39.5	23.7	0	
Total %	3.7	32.5	3.9	0	2	3.8	5.7	0	2.6	32.1	1.9	0	4.4	4.7	2.8	0	



MINNESOTA DEPT OF TRANSPORTATION

TRAFFIC DATA COLLECTION - METRO

Location : TH-65 AT 44TH AVE NE
 Ref.Pt.: 005.011
 JAMAR# 632 DR
 TURN MOVEMENT COUNT

File Name : TH-65 AT 44TH AVE NE 2009
 Site Code : 00000000
 Start Date : 4/15/2009
 Page No : 2

Start Time	TH 65 Southbound					44TH AVE NE Westbound					TH 65 Northbound					44TH AVE NE Eastbound					Int. Total
	Left	Thru	Right	Peds	App. Total	Left	Thru	Right	Peds	App. Total	Left	Thru	Right	Peds	App. Total	Left	Thru	Right	Peds	App. Total	
Peak Hour Analysis From 06:00 to 08:45 - Peak 1 of 1																					
Peak Hour for Entire Intersection Begins at 07:15																					
07:15	18	219	11	0	248	14	15	17	0	46	7	77	3	0	87	12	11	10	0	33	414
07:30	16	224	13	0	253	8	18	26	0	52	12	116	6	0	134	20	22	14	0	56	495
07:45	15	310	26	0	351	8	13	31	0	52	8	124	8	0	140	22	9	12	0	43	586
08:00	14	186	19	0	219	8	20	19	0	47	6	112	10	0	128	22	12	16	0	50	444
Total Volume	63	939	69	0	1071	38	66	93	0	197	33	429	27	0	489	76	54	52	0	182	1939
% App. Total																					
PHF	.875	.757	.663	.000	.763	.679	.825	.750	.000	.947	.688	.865	.675	.000	.873	.864	.614	.813	.000	.813	.827

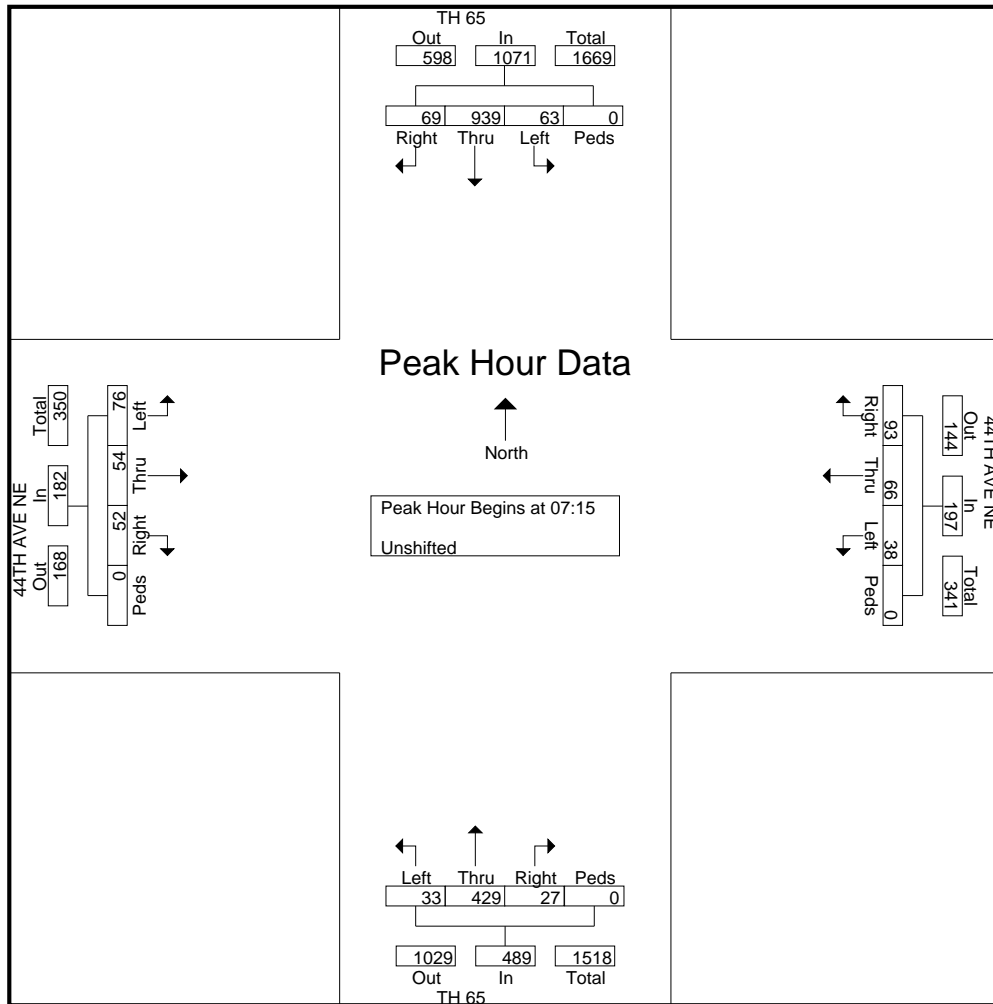



MINNESOTA DEPT OF TRANSPORTATION

TRAFFIC DATA COLLECTION - METRO

Location : TH-65 AT 44TH AVE NE
 Ref.Pt.: 005.011
 JAMAR# 632 DR
 TURN MOVEMENT COUNT

File Name : TH-65 AT 44TH AVE NE 2009
 Site Code : 00000000
 Start Date : 4/15/2009
 Page No : 3

Start Time	TH 65 Southbound					44TH AVE NE Westbound					TH 65 Northbound					44TH AVE NE Eastbound					Int. Total
	Left	Thru	Right	Peds	App. Total	Left	Thru	Right	Peds	App. Total	Left	Thru	Right	Peds	App. Total	Left	Thru	Right	Peds	App. Total	
Peak Hour Analysis From 15:00 to 17:45 - Peak 1 of 1																					
Peak Hour for Entire Intersection Begins at 16:00																					
16:00	24	186	27	0	237	11	41	45	0	97	20	219	13	0	252	35	34	22	0	91	677
16:15	28	195	24	0	247	18	31	34	0	83	12	270	11	0	293	22	24	17	0	63	686
16:30	20	188	28	0	236	15	36	44	0	95	27	250	16	0	293	54	76	17	0	147	771
16:45	30	181	20	0	231	12	35	36	0	83	33	300	8	0	341	32	36	12	0	80	735
Total Volume	102	750	99	0	951	56	143	159	0	358	92	1039	48	0	1179	143	170	68	0	381	2869
% App. Total	10.7	78.9	10.4	0		15.6	39.9	44.4	0		7.8	88.1	4.1	0		37.5	44.6	17.8	0		
PHF	.850	.962	.884	.000	.963	.778	.872	.883	.000	.923	.697	.866	.750	.000	.864	.662	.559	.773	.000	.648	.930

