



# MINNESOTA DEPT OF TRANSPORTATION

## TRAFFIC DATA COLLECTION - METRO

loc: th 65 @ 73rd ave ne 2003  
 ref pt: 008+00.665  
 data collected by: alliant eng  
 tmc: am noon pm

File Name : T.H. 65 at 73rd  
 Site Code : 00000015  
 Start Date : 8/13/2003  
 Page No : 1

**Groups Printed- Unshifted**

| Start Time | T.H. 65 Southbound |      |       |      |            | 73rd Ave. NE Westbound |      |       |      |            | T.H. 65 Northbound |      |       |      |            | 73rd Ave. NE Eastbound |      |       |      |            | Int. Total |
|------------|--------------------|------|-------|------|------------|------------------------|------|-------|------|------------|--------------------|------|-------|------|------------|------------------------|------|-------|------|------------|------------|
|            | Left               | Thru | Right | Peds | App. Total | Left                   | Thru | Right | Peds | App. Total | Left               | Thru | Right | Peds | App. Total | Left                   | Thru | Right | Peds | App. Total |            |
| 06:00      | 19                 | 282  | 26    | 0    | 327        | 22                     | 12   | 1     | 0    | 35         | 6                  | 68   | 5     | 0    | 79         | 4                      | 18   | 13    | 0    | 35         | 476        |
| 06:15      | 15                 | 261  | 29    | 0    | 305        | 25                     | 20   | 8     | 3    | 56         | 6                  | 86   | 10    | 0    | 102        | 7                      | 25   | 17    | 0    | 49         | 512        |
| 06:30      | 30                 | 439  | 27    | 0    | 496        | 26                     | 11   | 3     | 2    | 42         | 13                 | 110  | 16    | 0    | 139        | 10                     | 44   | 20    | 1    | 75         | 752        |
| 06:45      | 34                 | 359  | 42    | 0    | 435        | 30                     | 46   | 14    | 0    | 90         | 9                  | 109  | 17    | 0    | 135        | 13                     | 33   | 24    | 0    | 70         | 730        |
| Total      | 98                 | 1341 | 124   | 0    | 1563       | 103                    | 89   | 26    | 5    | 223        | 34                 | 373  | 48    | 0    | 455        | 34                     | 120  | 74    | 1    | 229        | 2470       |
| 07:00      | 21                 | 440  | 35    | 0    | 496        | 23                     | 19   | 14    | 0    | 56         | 8                  | 117  | 13    | 0    | 138        | 6                      | 23   | 26    | 2    | 57         | 747        |
| 07:15      | 27                 | 418  | 28    | 0    | 473        | 41                     | 25   | 16    | 0    | 82         | 21                 | 95   | 14    | 0    | 130        | 15                     | 24   | 28    | 1    | 68         | 753        |
| 07:30      | 17                 | 429  | 35    | 0    | 481        | 22                     | 31   | 8     | 0    | 61         | 18                 | 179  | 14    | 1    | 212        | 13                     | 37   | 11    | 0    | 61         | 815        |
| 07:45      | 24                 | 376  | 37    | 0    | 437        | 27                     | 21   | 7     | 0    | 55         | 17                 | 159  | 11    | 0    | 187        | 13                     | 34   | 26    | 1    | 74         | 753        |
| Total      | 89                 | 1663 | 135   | 0    | 1887       | 113                    | 96   | 45    | 0    | 254        | 64                 | 550  | 52    | 1    | 667        | 47                     | 118  | 91    | 4    | 260        | 3068       |
| 08:00      | 21                 | 303  | 32    | 0    | 356        | 19                     | 19   | 8     | 0    | 46         | 26                 | 136  | 10    | 0    | 172        | 5                      | 26   | 15    | 0    | 46         | 620        |
| 08:15      | 25                 | 274  | 21    | 0    | 320        | 25                     | 19   | 11    | 0    | 55         | 20                 | 146  | 10    | 0    | 176        | 9                      | 23   | 14    | 1    | 47         | 598        |
| 08:30      | 17                 | 255  | 26    | 0    | 298        | 27                     | 18   | 5     | 0    | 50         | 15                 | 145  | 11    | 0    | 171        | 4                      | 18   | 13    | 0    | 35         | 554        |
| 08:45      | 19                 | 171  | 18    | 1    | 209        | 29                     | 16   | 17    | 0    | 62         | 15                 | 147  | 17    | 0    | 179        | 7                      | 23   | 16    | 1    | 47         | 497        |
| Total      | 82                 | 1003 | 97    | 1    | 1183       | 100                    | 72   | 41    | 0    | 213        | 76                 | 574  | 48    | 0    | 698        | 25                     | 90   | 58    | 2    | 175        | 2269       |
| 11:00      | 9                  | 193  | 16    | 0    | 218        | 28                     | 37   | 21    | 0    | 86         | 30                 | 215  | 12    | 0    | 257        | 12                     | 23   | 9     | 1    | 45         | 606        |
| 11:15      | 11                 | 200  | 13    | 0    | 224        | 17                     | 31   | 18    | 1    | 67         | 26                 | 223  | 15    | 0    | 264        | 19                     | 24   | 21    | 1    | 65         | 620        |
| 11:30      | 24                 | 223  | 18    | 12   | 277        | 17                     | 28   | 18    | 0    | 63         | 25                 | 219  | 14    | 0    | 258        | 24                     | 24   | 20    | 11   | 79         | 677        |
| 11:45      | 10                 | 201  | 21    | 0    | 232        | 21                     | 42   | 36    | 0    | 99         | 20                 | 207  | 27    | 0    | 254        | 19                     | 34   | 20    | 0    | 73         | 658        |
| Total      | 54                 | 817  | 68    | 12   | 951        | 83                     | 138  | 93    | 1    | 315        | 101                | 864  | 68    | 0    | 1033       | 74                     | 105  | 70    | 13   | 262        | 2561       |
| 12:00      | 19                 | 224  | 24    | 0    | 267        | 18                     | 22   | 26    | 0    | 66         | 18                 | 279  | 10    | 0    | 307        | 17                     | 37   | 25    | 1    | 80         | 720        |
| 12:15      | 20                 | 209  | 13    | 0    | 242        | 14                     | 38   | 17    | 0    | 69         | 13                 | 210  | 28    | 1    | 252        | 26                     | 41   | 17    | 0    | 84         | 647        |
| 12:30      | 20                 | 225  | 16    | 0    | 261        | 21                     | 18   | 13    | 0    | 52         | 33                 | 232  | 16    | 0    | 281        | 25                     | 46   | 21    | 0    | 92         | 686        |
| 12:45      | 15                 | 217  | 22    | 0    | 254        | 21                     | 28   | 15    | 1    | 65         | 24                 | 230  | 20    | 1    | 275        | 14                     | 34   | 23    | 0    | 71         | 665        |
| Total      | 74                 | 875  | 75    | 0    | 1024       | 74                     | 106  | 71    | 1    | 252        | 88                 | 951  | 74    | 2    | 1115       | 82                     | 158  | 86    | 1    | 327        | 2718       |



# MINNESOTA DEPT OF TRANSPORTATION

## TRAFFIC DATA COLLECTION - METRO

File Name : T.H. 65 at 73rd  
 Site Code : 00000015  
 Start Date : 8/13/2003  
 Page No : 2

**Groups Printed- Unshifted**

| Start Time   | T.H. 65 Southbound |            |           |          |            | 73rd Ave. NE Westbound |            |            |          |            | T.H. 65 Northbound |             |           |          |             | 73rd Ave. NE Eastbound |            |            |          |            | Int. Total  |
|--------------|--------------------|------------|-----------|----------|------------|------------------------|------------|------------|----------|------------|--------------------|-------------|-----------|----------|-------------|------------------------|------------|------------|----------|------------|-------------|
|              | Left               | Thru       | Right     | Peds     | App. Total | Left                   | Thru       | Right      | Peds     | App. Total | Left               | Thru        | Right     | Peds     | App. Total  | Left                   | Thru       | Right      | Peds     | App. Total |             |
| 15:00        | 12                 | 199        | 13        | 0        | 224        | 38                     | 77         | 49         | 1        | 165        | 35                 | 291         | 12        | 0        | 338         | 25                     | 35         | 27         | 3        | 90         | 817         |
| 15:15        | 11                 | 210        | 19        | 0        | 240        | 18                     | 26         | 26         | 0        | 70         | 17                 | 321         | 18        | 0        | 356         | 35                     | 22         | 40         | 1        | 98         | 764         |
| 15:30        | 18                 | 210        | 23        | 0        | 251        | 20                     | 42         | 30         | 0        | 92         | 29                 | 388         | 20        | 0        | 437         | 64                     | 45         | 43         | 0        | 152        | 932         |
| 15:45        | 8                  | 192        | 20        | 0        | 220        | 26                     | 43         | 33         | 0        | 102        | 25                 | 302         | 17        | 0        | 344         | 26                     | 38         | 35         | 2        | 101        | 767         |
| <b>Total</b> | <b>49</b>          | <b>811</b> | <b>75</b> | <b>0</b> | <b>935</b> | <b>102</b>             | <b>188</b> | <b>138</b> | <b>1</b> | <b>429</b> | <b>106</b>         | <b>1302</b> | <b>67</b> | <b>0</b> | <b>1475</b> | <b>150</b>             | <b>140</b> | <b>145</b> | <b>6</b> | <b>441</b> | <b>3280</b> |
|              |                    |            |           |          |            |                        |            |            |          |            |                    |             |           |          |             |                        |            |            |          |            |             |
| 16:00        | 19                 | 203        | 15        | 0        | 237        | 23                     | 23         | 25         | 0        | 71         | 20                 | 373         | 16        | 0        | 409         | 59                     | 32         | 46         | 2        | 139        | 856         |
| 16:15        | 13                 | 192        | 13        | 0        | 218        | 29                     | 34         | 35         | 0        | 98         | 25                 | 313         | 20        | 0        | 358         | 34                     | 65         | 44         | 1        | 144        | 818         |
| 16:30        | 21                 | 242        | 18        | 2        | 283        | 39                     | 30         | 38         | 0        | 107        | 22                 | 438         | 29        | 0        | 489         | 54                     | 43         | 26         | 0        | 123        | 1002        |
| 16:45        | 14                 | 196        | 16        | 0        | 226        | 32                     | 32         | 28         | 1        | 93         | 27                 | 392         | 25        | 0        | 444         | 29                     | 38         | 24         | 0        | 91         | 854         |
| <b>Total</b> | <b>67</b>          | <b>833</b> | <b>62</b> | <b>2</b> | <b>964</b> | <b>123</b>             | <b>119</b> | <b>126</b> | <b>1</b> | <b>369</b> | <b>94</b>          | <b>1516</b> | <b>90</b> | <b>0</b> | <b>1700</b> | <b>176</b>             | <b>178</b> | <b>140</b> | <b>3</b> | <b>497</b> | <b>3530</b> |
|              |                    |            |           |          |            |                        |            |            |          |            |                    |             |           |          |             |                        |            |            |          |            |             |
| 17:00        | 13                 | 250        | 16        | 0        | 279        | 21                     | 33         | 41         | 0        | 95         | 23                 | 417         | 24        | 0        | 464         | 45                     | 54         | 29         | 3        | 131        | 969         |
| 17:15        | 9                  | 234        | 18        | 0        | 261        | 35                     | 29         | 30         | 0        | 94         | 25                 | 435         | 22        | 0        | 482         | 37                     | 29         | 25         | 1        | 92         | 929         |
| 17:30        | 12                 | 199        | 9         | 0        | 220        | 28                     | 38         | 34         | 2        | 102        | 19                 | 384         | 19        | 0        | 422         | 31                     | 48         | 14         | 0        | 93         | 837         |
| 17:45        | 17                 | 193        | 10        | 0        | 220        | 23                     | 25         | 25         | 2        | 75         | 25                 | 375         | 16        | 0        | 416         | 27                     | 25         | 24         | 3        | 79         | 790         |
| <b>Total</b> | <b>51</b>          | <b>876</b> | <b>53</b> | <b>0</b> | <b>980</b> | <b>107</b>             | <b>125</b> | <b>130</b> | <b>4</b> | <b>366</b> | <b>92</b>          | <b>1611</b> | <b>81</b> | <b>0</b> | <b>1784</b> | <b>140</b>             | <b>156</b> | <b>92</b>  | <b>7</b> | <b>395</b> | <b>3525</b> |
|              |                    |            |           |          |            |                        |            |            |          |            |                    |             |           |          |             |                        |            |            |          |            |             |
| Grand Total  | 564                | 8219       | 689       | 15       | 9487       | 805                    | 933        | 670        | 13       | 2421       | 655                | 7741        | 528       | 3        | 8927        | 728                    | 1065       | 756        | 37       | 2586       | 23421       |
| Apprch %     | 5.9                | 86.6       | 7.3       | 0.2      |            | 33.3                   | 38.5       | 27.7       | 0.5      |            | 7.3                | 86.7        | 5.9       | 0        |             | 28.2                   | 41.2       | 29.2       | 1.4      |            |             |
| Total %      | 2.4                | 35.1       | 2.9       | 0.1      | 40.5       | 3.4                    | 4          | 2.9        | 0.1      | 10.3       | 2.8                | 33.1        | 2.3       | 0        | 38.1        | 3.1                    | 4.5        | 3.2        | 0.2      | 11         |             |



# MINNESOTA DEPT OF TRANSPORTATION

## TRAFFIC DATA COLLECTION - METRO

File Name : T.H. 65 at 73rd  
 Site Code : 00000015  
 Start Date : 8/13/2003  
 Page No : 3

| Start Time   | T.H. 65 Southbound |      |       |      |            | 73rd Ave. NE Westbound |      |       |      |            | T.H. 65 Northbound |      |       |      |            | 73rd Ave. NE Eastbound |      |       |      |            | Int. Total |
|--|--------------------|------|-------|------|------------|------------------------|------|-------|------|------------|--------------------|------|-------|------|------------|------------------------|------|-------|------|------------|------------|
|  | Left               | Thru | Right | Peds | App. Total | Left                   | Thru | Right | Peds | App. Total | Left               | Thru | Right | Peds | App. Total | Left                   | Thru | Right | Peds | App. Total |            |
| Peak Hour Analysis From 06:00 to 09:45 - Peak 1 of 1 |                    |      |       |      |            |                        |      |       |      |            |                    |      |       |      |            |                        |      |       |      |            |            |
| Peak Hour for Entire Intersection Begins at 07:00    |                    |      |       |      |            |                        |      |       |      |            |                    |      |       |      |            |                        |      |       |      |            |            |
| 07:00  | 21                 | 440  | 35    | 0    | 496        | 23                     | 19   | 14    | 0    | 56         | 8                  | 117  | 13    | 0    | 138        | 6                      | 23   | 26    | 2    | 57         | 747        |
| 07:15  | 27                 | 418  | 28    | 0    | 473        | 41                     | 25   | 16    | 0    | 82         | 21                 | 95   | 14    | 0    | 130        | 15                     | 24   | 28    | 1    | 68         | 753        |
| 07:30  | 17                 | 429  | 35    | 0    | 481        | 22                     | 31   | 8     | 0    | 61         | 18                 | 179  | 14    | 1    | 212        | 13                     | 37   | 11    | 0    | 61         | 815        |
| 07:45  | 24                 | 376  | 37    | 0    | 437        | 27                     | 21   | 7     | 0    | 55         | 17                 | 159  | 11    | 0    | 187        | 13                     | 34   | 26    | 1    | 74         | 753        |
| Total Volume   | 89                 | 1663 | 135   | 0    | 1887       | 113                    | 96   | 45    | 0    | 254        | 64                 | 550  | 52    | 1    | 667        | 47                     | 118  | 91    | 4    | 260        | 3068       |
| % App. Total   | 4.7                | 88.1 | 7.2   | 0    |            | 44.5                   | 37.8 | 17.7  | 0    |            | 9.6                | 82.5 | 7.8   | 0.1  |            | 18.1                   | 45.4 | 35    | 1.5  |            |            |
| PHF  | .824               | .945 | .912  | .000 | .951       | .689                   | .774 | .703  | .000 | .774       | .762               | .768 | .929  | .250 | .787       | .783                   | .797 | .813  | .500 | .878       | .941       |

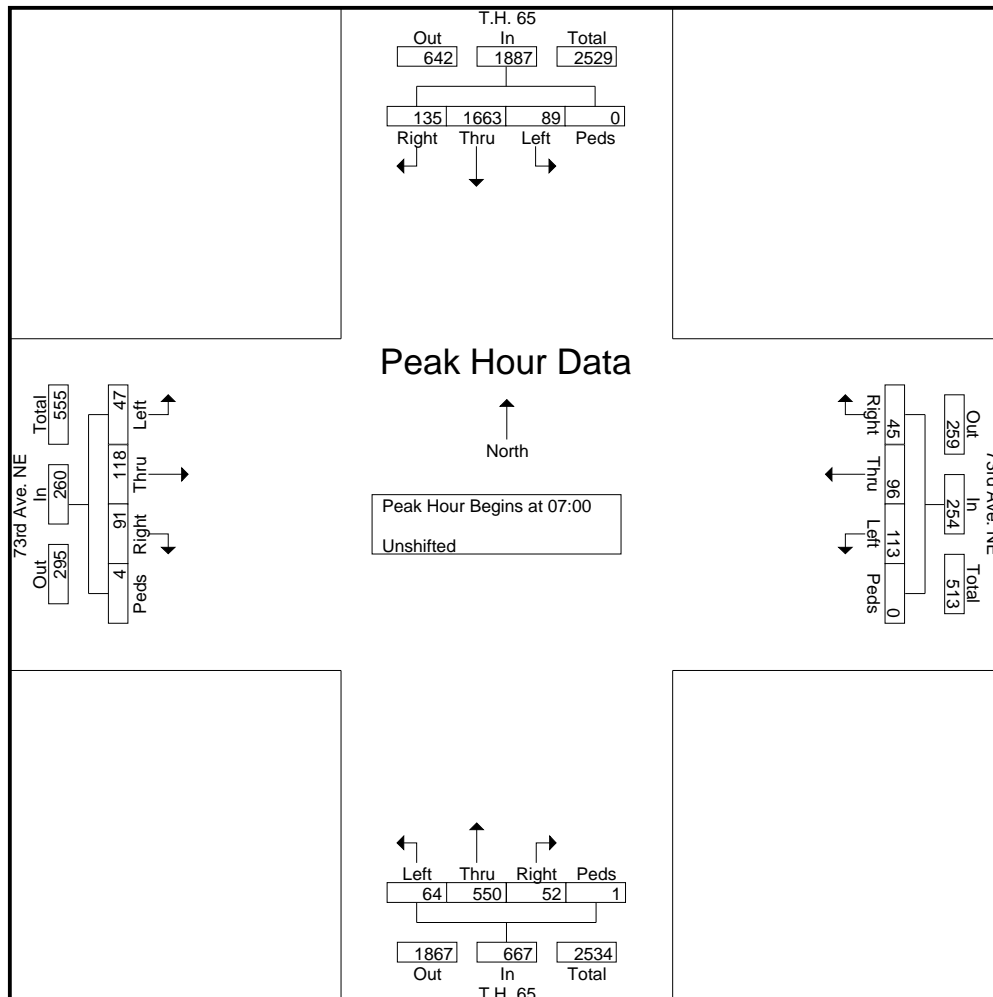



# MINNESOTA DEPT OF TRANSPORTATION

## TRAFFIC DATA COLLECTION - METRO

File Name : T.H. 65 at 73rd  
 Site Code : 00000015  
 Start Date : 8/13/2003  
 Page No : 4

| Start Time   | T.H. 65 Southbound |            |           |      |            | 73rd Ave. NE Westbound |           |           |          |            | T.H. 65 Northbound |            |           |      |            | 73rd Ave. NE Eastbound |           |           |      |            | Int. Total |
|--|--------------------|------------|-----------|------|------------|------------------------|-----------|-----------|----------|------------|--------------------|------------|-----------|------|------------|------------------------|-----------|-----------|------|------------|------------|
|  | Left               | Thru       | Right     | Peds | App. Total | Left                   | Thru      | Right     | Peds     | App. Total | Left               | Thru       | Right     | Peds | App. Total | Left                   | Thru      | Right     | Peds | App. Total |            |
| Peak Hour Analysis From 10:00 to 13:45 - Peak 1 of 1 |                    |            |           |      |            |                        |           |           |          |            |                    |            |           |      |            |                        |           |           |      |            |            |
| Peak Hour for Entire Intersection Begins at 12:00    |                    |            |           |      |            |                        |           |           |          |            |                    |            |           |      |            |                        |           |           |      |            |            |
| 12:00  | 19                 | 224        | <b>24</b> | 0    | <b>267</b> | 18                     | 22        | <b>26</b> | 0        | 66         | 18                 | <b>279</b> | 10        | 0    | <b>307</b> | 17                     | 37        | <b>25</b> | 1    | 80         | <b>720</b> |
| 12:15  | <b>20</b>          | 209        | 13        | 0    | 242        | 14                     | <b>38</b> | 17        | 0        | <b>69</b>  | 13                 | 210        | <b>28</b> | 1    | 252        | <b>26</b>              | 41        | 17        | 0    | 84         | 647        |
| 12:30  | 20                 | <b>225</b> | 16        | 0    | 261        | <b>21</b>              | 18        | 13        | 0        | 52         | <b>33</b>          | 232        | 16        | 0    | 281        | 25                     | <b>46</b> | 21        | 0    | <b>92</b>  | 686        |
| 12:45  | 15                 | 217        | 22        | 0    | 254        | 21                     | 28        | 15        | <b>1</b> | 65         | 24                 | 230        | 20        | 1    | 275        | 14                     | 34        | 23        | 0    | 71         | 665        |
| Total Volume   | 74                 | 875        | 75        | 0    | 1024       | 74                     | 106       | 71        | 1        | 252        | 88                 | 951        | 74        | 2    | 1115       | 82                     | 158       | 86        | 1    | 327        | 2718       |
| % App. Total   | 7.2                | 85.4       | 7.3       | 0    |            | 29.4                   | 42.1      | 28.2      | 0.4      |            | 7.9                | 85.3       | 6.6       | 0.2  |            | 25.1                   | 48.3      | 26.3      | 0.3  |            |            |
| PHF  | .925               | .972       | .781      | .000 | .959       | .881                   | .697      | .683      | .250     | .913       | .667               | .852       | .661      | .500 | .908       | .788                   | .859      | .860      | .250 | .889       | .944       |

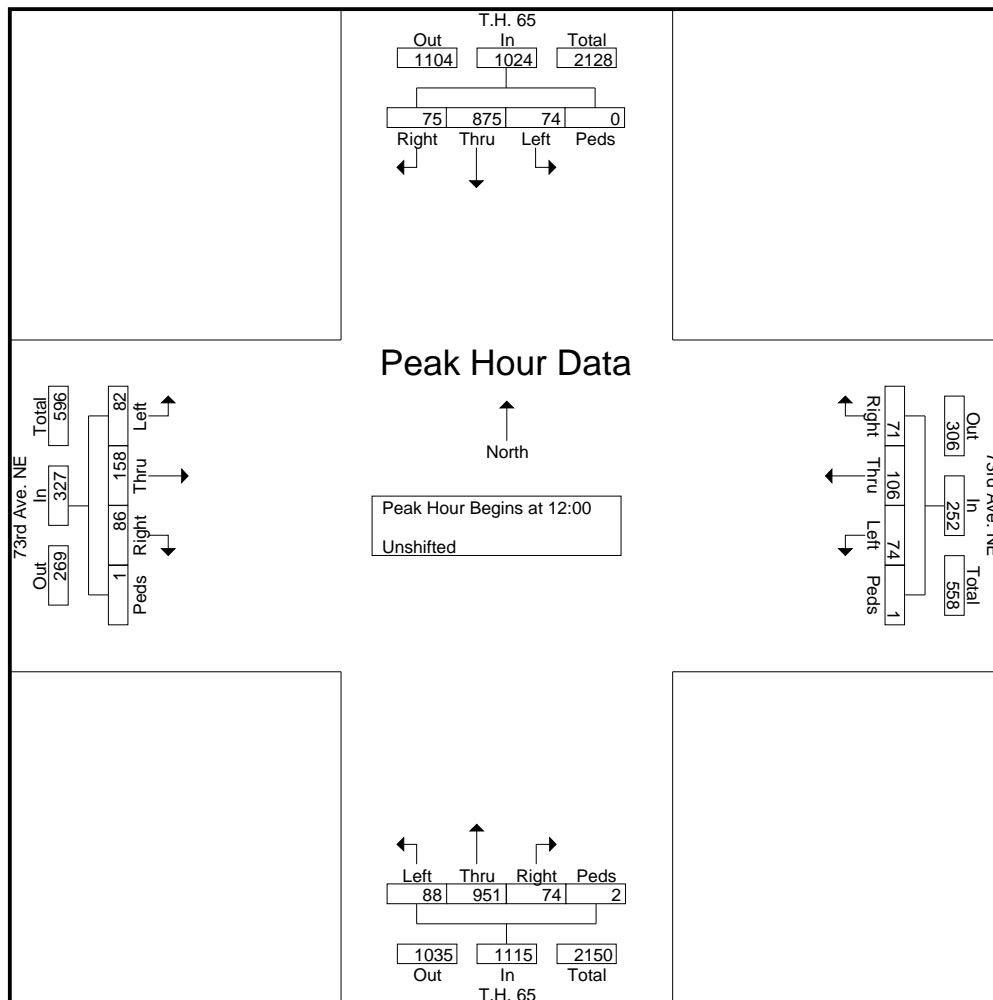



# MINNESOTA DEPT OF TRANSPORTATION

## TRAFFIC DATA COLLECTION - METRO

File Name : T.H. 65 at 73rd  
 Site Code : 00000015  
 Start Date : 8/13/2003  
 Page No : 5

| Start Time   | T.H. 65 Southbound |      |       |      |            | 73rd Ave. NE Westbound |      |       |      |            | T.H. 65 Northbound |      |       |      |            | 73rd Ave. NE Eastbound |      |       |      |            | Int. Total |
|--|--------------------|------|-------|------|------------|------------------------|------|-------|------|------------|--------------------|------|-------|------|------------|------------------------|------|-------|------|------------|------------|
|  | Left               | Thru | Right | Peds | App. Total | Left                   | Thru | Right | Peds | App. Total | Left               | Thru | Right | Peds | App. Total | Left                   | Thru | Right | Peds | App. Total |            |
| Peak Hour Analysis From 14:00 to 17:45 - Peak 1 of 1 |                    |      |       |      |            |                        |      |       |      |            |                    |      |       |      |            |                        |      |       |      |            |            |
| Peak Hour for Entire Intersection Begins at 16:30    |                    |      |       |      |            |                        |      |       |      |            |                    |      |       |      |            |                        |      |       |      |            |            |
| 16:30  | 21                 | 242  | 18    | 2    | 283        | 39                     | 30   | 38    | 0    | 107        | 22                 | 438  | 29    | 0    | 489        | 54                     | 43   | 26    | 0    | 123        | 1002       |
| 16:45  | 14                 | 196  | 16    | 0    | 226        | 32                     | 32   | 28    | 1    | 93         | 27                 | 392  | 25    | 0    | 444        | 29                     | 38   | 24    | 0    | 91         | 854        |
| 17:00  | 13                 | 250  | 16    | 0    | 279        | 21                     | 33   | 41    | 0    | 95         | 23                 | 417  | 24    | 0    | 464        | 45                     | 54   | 29    | 3    | 131        | 969        |
| 17:15  | 9                  | 234  | 18    | 0    | 261        | 35                     | 29   | 30    | 0    | 94         | 25                 | 435  | 22    | 0    | 482        | 37                     | 29   | 25    | 1    | 92         | 929        |
| Total Volume   | 57                 | 922  | 68    | 2    | 1049       | 127                    | 124  | 137   | 1    | 389        | 97                 | 1682 | 100   | 0    | 1879       | 165                    | 164  | 104   | 4    | 437        | 3754       |
| % App. Total   | 5.4                | 87.9 | 6.5   | 0.2  |            | 32.6                   | 31.9 | 35.2  | 0.3  |            | 5.2                | 89.5 | 5.3   | 0    |            | 37.8                   | 37.5 | 23.8  | 0.9  |            |            |
| PHF  | .679               | .922 | .944  | .250 | .927       | .814                   | .939 | .835  | .250 | .909       | .898               | .960 | .862  | .000 | .961       | .764                   | .759 | .897  | .333 | .834       | .937       |

