



# MINNESOTA DEPT OF TRANSPORTATION

## TRAFFIC DATA COLLECTION - METRO

Loc: th 65 @ th 242 2003  
 ref pt: 015+00.420  
 data collected by: alliant eng  
 turn movement count

File Name : T.H. 65 at T.H. 242  
 Site Code : 00000028  
 Start Date : 8/27/2003  
 Page No : 1

### Groups Printed- Unshifted

Start Time	Southbound					Westbound					Northbound					Eastbound					Int. Total
	Left	Thru	Right	Peds	App. Total	Left	Thru	Right	Peds	App. Total	Left	Thru	Right	Peds	App. Total	Left	Thru	Right	Peds	App. Total	
06:00	23	433	13	0	469	15	26	9	0	50	7	60	3	0	70	11	45	4	0	60	649
06:15	38	544	48	0	630	24	35	7	0	66	12	116	11	0	139	20	43	37	0	100	935
06:30	34	457	60	0	551	18	46	13	0	77	15	127	7	0	149	12	61	30	0	103	880
06:45	50	511	38	0	599	19	49	8	0	76	20	133	7	0	160	16	47	25	0	88	923
Total	145	1945	159	0	2249	76	156	37	0	269	54	436	28	0	518	59	196	96	0	351	3387
07:00	39	473	61	0	573	33	57	9	0	99	15	131	8	0	154	27	50	44	0	121	947
07:15	32	514	50	0	596	33	50	18	0	101	16	158	9	0	183	13	59	28	0	100	980
07:30	55	540	49	0	644	29	57	13	0	99	26	136	12	0	174	13	52	47	0	112	1029
07:45	54	385	42	0	481	40	38	14	1	93	32	131	12	0	175	18	61	39	0	118	867
Total	180	1912	202	0	2294	135	202	54	1	392	89	556	41	0	686	71	222	158	0	451	3823
08:00	18	373	36	0	427	20	31	13	0	64	21	126	13	0	160	18	52	35	0	105	756
08:15	41	317	30	0	388	22	44	9	0	75	25	123	8	0	156	17	38	46	0	101	720
08:30	35	303	60	0	398	28	52	13	0	93	21	109	7	0	137	16	39	28	0	83	711
08:45	29	209	15	0	253	23	47	11	0	81	27	128	12	0	167	19	49	26	0	94	595
Total	123	1202	141	0	1466	93	174	46	0	313	94	486	40	0	620	70	178	135	0	383	2782
11:00	27	203	19	0	249	38	43	14	0	95	30	158	9	0	197	34	37	27	0	98	639
11:15	27	180	21	0	228	21	64	20	0	105	23	145	11	0	179	36	54	21	0	111	623
11:30	32	218	23	1	274	27	67	16	0	110	26	243	7	1	277	47	53	24	0	124	785
11:45	45	166	21	0	232	30	59	15	0	104	47	205	21	0	273	36	53	29	0	118	727
Total	131	767	84	1	983	116	233	65	0	414	126	751	48	1	926	153	197	101	0	451	2774
12:00	52	194	46	0	292	33	63	20	2	118	38	192	13	0	243	34	48	29	0	111	764
12:15	34	197	43	0	274	40	48	28	0	116	37	249	4	0	290	44	66	19	0	129	809
12:30	35	178	39	0	252	32	51	24	0	107	45	232	22	0	299	34	62	37	0	133	791
12:45	34	200	42	0	276	37	62	23	0	122	38	177	16	0	231	40	47	31	0	118	747
Total	155	769	170	0	1094	142	224	95	2	463	158	850	55	0	1063	152	223	116	0	491	3111



# MINNESOTA DEPT OF TRANSPORTATION

## TRAFFIC DATA COLLECTION - METRO

File Name : T.H. 65 at T.H. 242  
 Site Code : 00000028  
 Start Date : 8/27/2003  
 Page No : 2

**Groups Printed- Unshifted**

Start Time	Southbound					Westbound					Northbound					Eastbound					Int. Total
	Left	Thru	Right	Peds	App. Total	Left	Thru	Right	Peds	App. Total	Left	Thru	Right	Peds	App. Total	Left	Thru	Right	Peds	App. Total	
15:00	34	193	11	0	238	34	72	20	0	126	37	361	11	0	409	48	67	17	0	132	905
15:15	32	185	8	0	225	41	105	22	1	169	51	401	7	0	459	36	51	34	0	121	974
15:30	43	213	7	0	263	40	100	26	0	166	32	455	6	0	493	66	70	31	0	167	1089
15:45	23	184	15	2	224	34	105	31	0	170	48	419	7	0	474	65	63	25	0	153	1021
<b>Total</b>	<b>132</b>	<b>775</b>	<b>41</b>	<b>2</b>	<b>950</b>	<b>149</b>	<b>382</b>	<b>99</b>	<b>1</b>	<b>631</b>	<b>168</b>	<b>1636</b>	<b>31</b>	<b>0</b>	<b>1835</b>	<b>215</b>	<b>251</b>	<b>107</b>	<b>0</b>	<b>573</b>	<b>3989</b>
16:00	32	191	15	0	238	34	103	41	1	179	51	427	7	1	486	57	50	29	0	136	1039
16:15	24	194	24	0	242	32	106	55	0	193	45	442	10	0	497	64	63	22	0	149	1081
16:30	42	178	30	0	250	44	123	41	1	209	40	423	1	0	464	80	70	26	0	176	1099
16:45	33	216	36	0	285	44	111	41	0	196	39	422	7	0	468	92	65	36	0	193	1142
<b>Total</b>	<b>131</b>	<b>779</b>	<b>105</b>	<b>0</b>	<b>1015</b>	<b>154</b>	<b>443</b>	<b>178</b>	<b>2</b>	<b>777</b>	<b>175</b>	<b>1714</b>	<b>25</b>	<b>1</b>	<b>1915</b>	<b>293</b>	<b>248</b>	<b>113</b>	<b>0</b>	<b>654</b>	<b>4361</b>
17:00	35	233	38	0	306	56	105	45	0	206	49	496	13	0	558	81	75	29	0	185	1255
17:15	36	195	41	0	272	44	110	64	0	218	51	411	6	1	469	72	98	29	0	199	1158
17:30	38	213	41	0	292	40	83	55	0	178	46	402	13	0	461	59	88	41	0	188	1119
17:45	38	212	27	0	277	56	108	38	0	202	40	405	15	8	468	83	92	31	0	206	1153
<b>Total</b>	<b>147</b>	<b>853</b>	<b>147</b>	<b>0</b>	<b>1147</b>	<b>196</b>	<b>406</b>	<b>202</b>	<b>0</b>	<b>804</b>	<b>186</b>	<b>1714</b>	<b>47</b>	<b>9</b>	<b>1956</b>	<b>295</b>	<b>353</b>	<b>130</b>	<b>0</b>	<b>778</b>	<b>4685</b>
Grand Total	1144	9002	1049	3	11198	1061	2220	776	6	4063	1050	8143	315	11	9519	1308	1868	956	0	4132	28912
Apprch %	10.2	80.4	9.4	0		26.1	54.6	19.1	0.1		11	85.5	3.3	0.1		31.7	45.2	23.1	0		
Total %	4	31.1	3.6	0	38.7	3.7	7.7	2.7	0	14.1	3.6	28.2	1.1	0	32.9	4.5	6.5	3.3	0	14.3	



# MINNESOTA DEPT OF TRANSPORTATION

## TRAFFIC DATA COLLECTION - METRO

File Name : T.H. 65 at T.H. 242  
 Site Code : 00000028  
 Start Date : 8/27/2003  
 Page No : 3

Start Time	Southbound					Westbound					Northbound					Eastbound					Int. Total
	Left	Thru	Right	Peds	App. Total	Left	Thru	Right	Peds	App. Total	Left	Thru	Right	Peds	App. Total	Left	Thru	Right	Peds	App. Total	
Peak Hour Analysis From 06:00 to 09:45 - Peak 1 of 1																					
Peak Hour for Entire Intersection Begins at 06:45																					
06:45	50	511	38	0	599	19	49	8	0	76	20	133	7	0	160	16	47	25	0	88	923
07:00	39	473	61	0	573	33	57	9	0	99	15	131	8	0	154	27	50	44	0	121	947
07:15	32	514	50	0	596	33	50	18	0	101	16	158	9	0	183	13	59	28	0	100	980
07:30	55	540	49	0	644	29	57	13	0	99	26	136	12	0	174	13	52	47	0	112	1029
Total Volume	176	2038	198	0	2412	114	213	48	0	375	77	558	36	0	671	69	208	144	0	421	3879
% App. Total	7.3	84.5	8.2	0		30.4	56.8	12.8	0		11.5	83.2	5.4	0		16.4	49.4	34.2	0		
PHF	.800	.944	.811	.000	.936	.864	.934	.667	.000	.928	.740	.883	.750	.000	.917	.639	.881	.766	.000	.870	.942

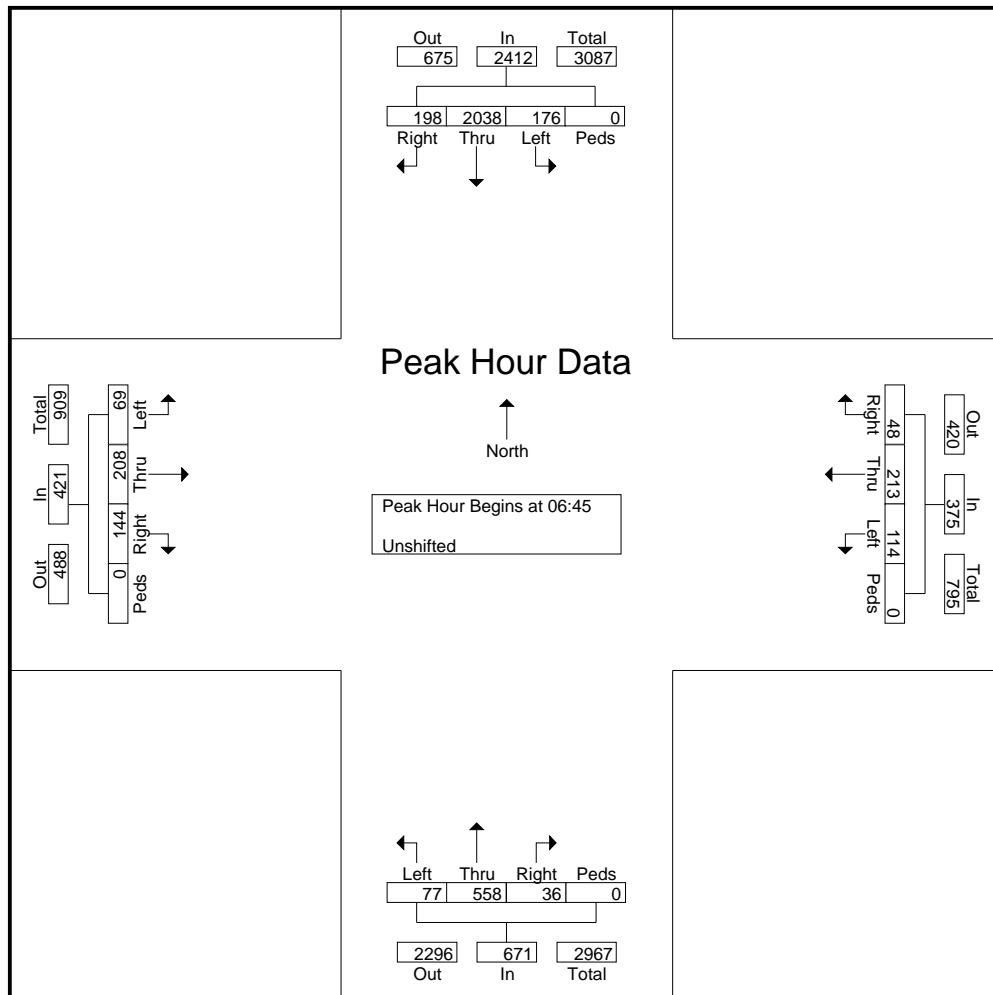



# MINNESOTA DEPT OF TRANSPORTATION

## TRAFFIC DATA COLLECTION - METRO

File Name : T.H. 65 at T.H. 242  
 Site Code : 00000028  
 Start Date : 8/27/2003  
 Page No : 4

Start Time	Southbound					Westbound					Northbound					Eastbound					Int. Total
	Left	Thru	Right	Peds	App. Total	Left	Thru	Right	Peds	App. Total	Left	Thru	Right	Peds	App. Total	Left	Thru	Right	Peds	App. Total	
Peak Hour Analysis From 10:00 to 13:45 - Peak 1 of 1																					
Peak Hour for Entire Intersection Begins at 12:00																					
12:00	52	194	46	0	292	33	63	20	2	118	38	192	13	0	243	34	48	29	0	111	764
12:15	34	197	43	0	274	40	48	28	0	116	37	249	4	0	290	44	66	19	0	129	809
12:30	35	178	39	0	252	32	51	24	0	107	45	232	22	0	299	34	62	37	0	133	791
12:45	34	200	42	0	276	37	62	23	0	122	38	177	16	0	231	40	47	31	0	118	747
Total Volume	155	769	170	0	1094	142	224	95	2	463	158	850	55	0	1063	152	223	116	0	491	3111
% App. Total	14.2	70.3	15.5	0		30.7	48.4	20.5	0.4		14.9	80	5.2	0		31	45.4	23.6	0		
PHF	.745	.961	.924	.000	.937	.888	.889	.848	.250	.949	.878	.853	.625	.000	.889	.864	.845	.784	.000	.923	.961

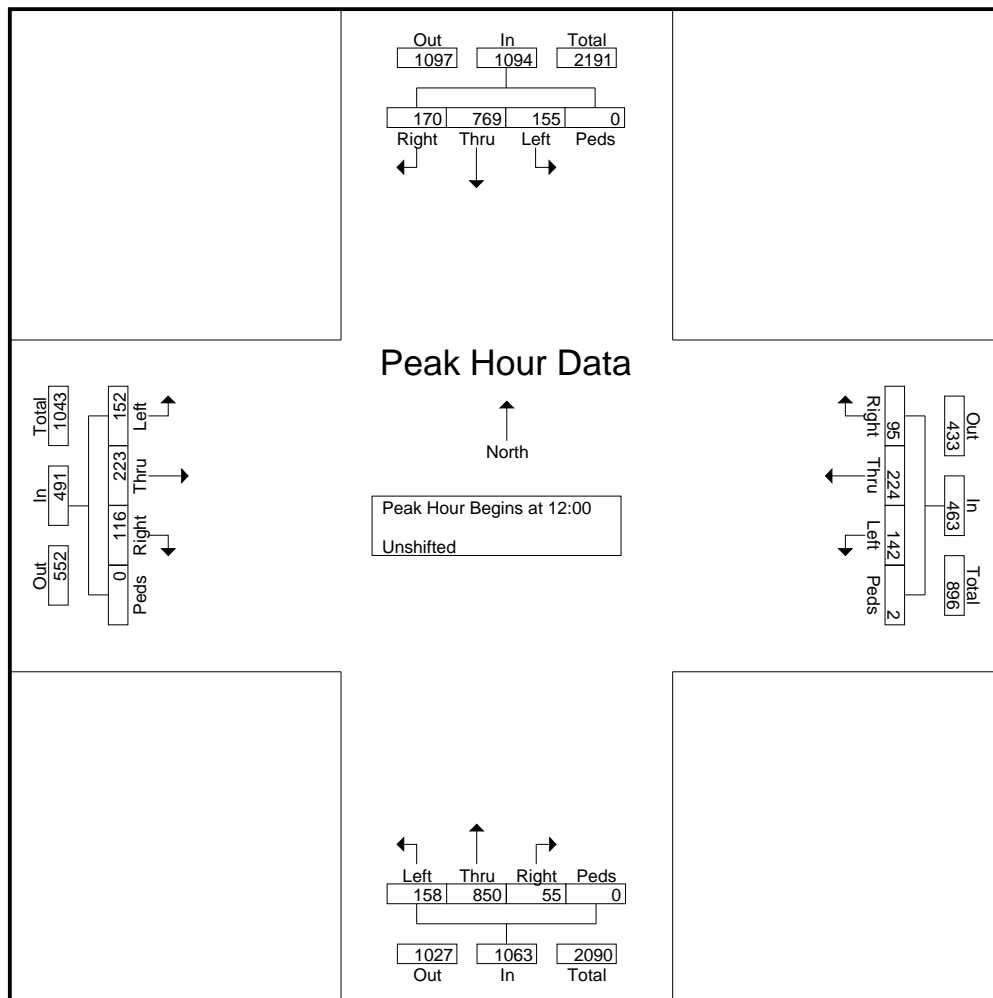



# MINNESOTA DEPT OF TRANSPORTATION

## TRAFFIC DATA COLLECTION - METRO

File Name : T.H. 65 at T.H. 242  
 Site Code : 00000028  
 Start Date : 8/27/2003  
 Page No : 5

Start Time	Southbound					Westbound					Northbound					Eastbound					Int. Total
	Left	Thru	Right	Peds	App. Total	Left	Thru	Right	Peds	App. Total	Left	Thru	Right	Peds	App. Total	Left	Thru	Right	Peds	App. Total	
Peak Hour Analysis From 14:00 to 17:45 - Peak 1 of 1																					
Peak Hour for Entire Intersection Begins at 17:00																					
17:00	35	233	38	0	306	56	105	45	0	206	49	496	13	0	558	81	75	29	0	185	1255
17:15	36	195	41	0	272	44	110	64	0	218	51	411	6	1	469	72	98	29	0	199	1158
17:30	38	213	41	0	292	40	83	55	0	178	46	402	13	0	461	59	88	41	0	188	1119
17:45	38	212	27	0	277	56	108	38	0	202	40	405	15	8	468	83	92	31	0	206	1153
Total Volume	147	853	147	0	1147	196	406	202	0	804	186	1714	47	9	1956	295	353	130	0	778	4685
% App. Total	12.8	74.4	12.8	0		24.4	50.5	25.1	0		9.5	87.6	2.4	0.5		37.9	45.4	16.7	0		
PHF	.967	.915	.896	.000	.937	.875	.923	.789	.000	.922	.912	.864	.783	.281	.876	.889	.901	.793	.000	.944	.933

