

**MINNESOTA DEPARTMENT OF TRANSPORTATION**  
**TRAFFIC DATA COLLECTION - Metro**

TH-65 at 181st Ave  
 Ref.Pt.: 022+00.392  
 Video by XY  
 TURN MOVEMENT COUNT

File Name : TH-65 at 181st Ave 2017  
 Site Code :  
 Start Date : 2/1/2017  
 Page No : 1

| Groups Printed- Cars + - Trucks |                  |      |       |      |                     |      |       |      |                  |      |       |      |                     |      |       |      |            |
|---------------------------------|------------------|------|-------|------|---------------------|------|-------|------|------------------|------|-------|------|---------------------|------|-------|------|------------|
| Start Time                      | TH-65 Southbound |      |       |      | 181st Ave Westbound |      |       |      | TH-65 Northbound |      |       |      | 181st Ave Eastbound |      |       |      | Int. Total |
|                                 | Left             | Thru | Right | Peds | Left                | Thru | Right | Peds | Left             | Thru | Right | Peds | Left                | Thru | Right | Peds |            |
| 06:00                           | 0                | 423  | 0     | 0    | 3                   | 0    | 0     | 0    | 0                | 39   | 0     | 0    | 2                   | 0    | 8     | 0    | 475        |
| 06:15                           | 1                | 429  | 0     | 0    | 4                   | 2    | 0     | 0    | 1                | 59   | 0     | 0    | 2                   | 0    | 9     | 0    | 507        |
| 06:30                           | 0                | 510  | 3     | 0    | 4                   | 1    | 1     | 0    | 1                | 79   | 0     | 0    | 0                   | 0    | 10    | 0    | 609        |
| 06:45                           | 0                | 413  | 4     | 0    | 4                   | 6    | 0     | 0    | 0                | 93   | 0     | 0    | 0                   | 0    | 9     | 0    | 529        |
| Total                           | 1                | 1775 | 7     | 0    | 15                  | 9    | 1     | 0    | 2                | 270  | 0     | 0    | 4                   | 0    | 36    | 0    | 2120       |
| 07:00                           | 3                | 420  | 0     | 0    | 7                   | 3    | 0     | 0    | 0                | 102  | 0     | 0    | 3                   | 1    | 14    | 0    | 553        |
| 07:15                           | 0                | 429  | 2     | 0    | 2                   | 0    | 1     | 0    | 3                | 83   | 0     | 0    | 1                   | 0    | 11    | 0    | 532        |
| 07:30                           | 0                | 421  | 0     | 0    | 1                   | 3    | 0     | 0    | 0                | 126  | 0     | 0    | 1                   | 2    | 10    | 0    | 564        |
| 07:45                           | 1                | 408  | 1     | 0    | 9                   | 2    | 0     | 0    | 2                | 116  | 0     | 0    | 1                   | 0    | 15    | 0    | 555        |
| Total                           | 4                | 1678 | 3     | 0    | 19                  | 8    | 1     | 0    | 5                | 427  | 0     | 0    | 6                   | 3    | 50    | 0    | 2204       |
| 08:00                           | 0                | 358  | 0     | 0    | 4                   | 2    | 0     | 0    | 2                | 115  | 0     | 0    | 2                   | 1    | 12    | 0    | 496        |
| 08:15                           | 1                | 260  | 3     | 0    | 3                   | 5    | 0     | 0    | 6                | 120  | 0     | 0    | 3                   | 1    | 6     | 0    | 408        |
| 08:30                           | 0                | 282  | 1     | 0    | 3                   | 1    | 0     | 0    | 3                | 110  | 2     | 0    | 2                   | 1    | 6     | 0    | 411        |
| 08:45                           | 0                | 263  | 0     | 0    | 2                   | 2    | 1     | 0    | 5                | 104  | 1     | 0    | 3                   | 1    | 9     | 0    | 391        |
| Total                           | 1                | 1163 | 4     | 0    | 12                  | 10   | 1     | 0    | 16               | 449  | 3     | 0    | 10                  | 4    | 33    | 0    | 1706       |
| 09:00                           | 0                | 241  | 1     | 0    | 4                   | 0    | 0     | 0    | 4                | 84   | 1     | 0    | 1                   | 0    | 9     | 0    | 345        |
| 09:15                           | 0                | 207  | 2     | 0    | 2                   | 1    | 0     | 0    | 7                | 114  | 2     | 0    | 2                   | 0    | 14    | 0    | 351        |
| 09:30                           | 1                | 230  | 3     | 0    | 2                   | 0    | 0     | 0    | 9                | 125  | 2     | 0    | 0                   | 0    | 6     | 0    | 378        |
| 09:45                           | 2                | 183  | 3     | 0    | 7                   | 3    | 0     | 0    | 5                | 110  | 1     | 0    | 2                   | 0    | 7     | 0    | 323        |
| Total                           | 3                | 861  | 9     | 0    | 15                  | 4    | 0     | 0    | 25               | 433  | 6     | 0    | 5                   | 0    | 36    | 0    | 1397       |
| 10:00                           | 1                | 176  | 2     | 0    | 4                   | 0    | 1     | 0    | 3                | 102  | 0     | 0    | 1                   | 1    | 7     | 0    | 298        |
| 10:15                           | 0                | 170  | 1     | 0    | 2                   | 0    | 1     | 0    | 8                | 94   | 1     | 0    | 1                   | 1    | 8     | 0    | 287        |
| 10:30                           | 0                | 166  | 2     | 0    | 6                   | 0    | 0     | 0    | 9                | 128  | 2     | 0    | 2                   | 1    | 5     | 0    | 321        |
| 10:45                           | 0                | 168  | 7     | 0    | 2                   | 3    | 0     | 0    | 8                | 129  | 2     | 0    | 1                   | 0    | 12    | 0    | 332        |
| Total                           | 1                | 680  | 12    | 0    | 14                  | 3    | 2     | 0    | 28               | 453  | 5     | 0    | 5                   | 3    | 32    | 0    | 1238       |
| 11:00                           | 0                | 158  | 1     | 0    | 4                   | 0    | 1     | 0    | 10               | 133  | 0     | 0    | 1                   | 0    | 4     | 0    | 312        |
| 11:15                           | 1                | 161  | 3     | 0    | 2                   | 0    | 0     | 0    | 3                | 136  | 0     | 0    | 3                   | 1    | 7     | 0    | 317        |
| 11:30                           | 1                | 158  | 3     | 0    | 5                   | 2    | 0     | 0    | 3                | 146  | 2     | 0    | 1                   | 2    | 8     | 0    | 331        |
| 11:45                           | 1                | 161  | 1     | 0    | 2                   | 3    | 0     | 0    | 11               | 141  | 1     | 0    | 1                   | 0    | 5     | 0    | 327        |
| Total                           | 3                | 638  | 8     | 0    | 13                  | 5    | 1     | 0    | 27               | 556  | 3     | 0    | 6                   | 3    | 24    | 0    | 1287       |
| 12:00                           | 0                | 151  | 5     | 0    | 5                   | 0    | 0     | 0    | 9                | 147  | 0     | 0    | 6                   | 2    | 10    | 0    | 335        |
| 12:15                           | 0                | 150  | 6     | 0    | 5                   | 3    | 0     | 0    | 11               | 146  | 2     | 0    | 7                   | 1    | 10    | 0    | 341        |
| 12:30                           | 0                | 152  | 4     | 0    | 3                   | 2    | 0     | 0    | 10               | 155  | 4     | 0    | 4                   | 1    | 9     | 0    | 344        |
| 12:45                           | 0                | 132  | 3     | 0    | 6                   | 3    | 0     | 0    | 5                | 154  | 0     | 0    | 11                  | 0    | 3     | 0    | 317        |
| Total                           | 0                | 585  | 18    | 0    | 19                  | 8    | 0     | 0    | 35               | 602  | 6     | 0    | 28                  | 4    | 32    | 0    | 1337       |
| 13:00                           | 1                | 134  | 2     | 0    | 6                   | 0    | 1     | 0    | 10               | 161  | 0     | 1    | 5                   | 1    | 7     | 0    | 329        |
| 13:15                           | 0                | 165  | 0     | 0    | 2                   | 0    | 0     | 0    | 9                | 159  | 1     | 0    | 1                   | 2    | 10    | 0    | 349        |
| 13:30                           | 0                | 158  | 4     | 0    | 2                   | 0    | 0     | 0    | 10               | 205  | 1     | 0    | 12                  | 1    | 2     | 0    | 395        |
| 13:45                           | 1                | 129  | 2     | 0    | 3                   | 0    | 0     | 0    | 15               | 180  | 1     | 0    | 3                   | 0    | 11    | 0    | 345        |
| Total                           | 2                | 586  | 8     | 0    | 13                  | 0    | 1     | 0    | 44               | 705  | 3     | 1    | 21                  | 4    | 30    | 0    | 1418       |
| 14:00                           | 0                | 164  | 4     | 0    | 3                   | 0    | 0     | 0    | 6                | 213  | 2     | 0    | 2                   | 1    | 14    | 1    | 410        |
| 14:15                           | 0                | 190  | 4     | 0    | 4                   | 0    | 0     | 0    | 16               | 179  | 3     | 0    | 5                   | 0    | 8     | 0    | 409        |
| 14:30                           | 1                | 177  | 1     | 0    | 3                   | 2    | 0     | 0    | 9                | 300  | 3     | 0    | 3                   | 0    | 6     | 0    | 505        |



# MINNESOTA DEPARTMENT OF TRANSPORTATION

## TRAFFIC DATA COLLECTION - Metro

TH-65 at 181st Ave  
 Ref.Pt.: 022+00.392  
 Video by XY  
 TURN MOVEMENT COUNT

File Name : TH-65 at 181st Ave 2017  
 Site Code :  
 Start Date : 2/1/2017  
 Page No : 3

| Start Time   | TH-65 Southbound |      |       |      |            | 181st Ave Westbound |      |       |      |            | TH-65 Northbound |      |       |      |            | 181st Ave Eastbound |      |       |      |            | Int. Total |
|--|------------------|------|-------|------|------------|---------------------|------|-------|------|------------|------------------|------|-------|------|------------|---------------------|------|-------|------|------------|------------|
|  | Left             | Thru | Right | Peds | App. Total | Left                | Thru | Right | Peds | App. Total | Left             | Thru | Right | Peds | App. Total | Left                | Thru | Right | Peds | App. Total |            |
| Peak Hour Analysis From 06:00 to 11:45 - Peak 1 of 1 |                  |      |       |      |            |                     |      |       |      |            |                  |      |       |      |            |                     |      |       |      |            |            |
| Peak Hour for Entire Intersection Begins at 06:30    |                  |      |       |      |            |                     |      |       |      |            |                  |      |       |      |            |                     |      |       |      |            |            |
| 06:30  | 0                | 510  | 3     | 0    | 513        | 4                   | 1    | 1     |      |            | 0                | 93   | 0     | 0    | 93         | 0                   | 0    | 9     | 0    | 9          | 609        |
| 06:45  | 0                | 413  | 4     |      |            |                     | 6    |       |      | 10         | 0                | 102  | 0     | 0    | 102        | 3                   | 1    | 14    |      | 18         | 529        |
| 07:00  | 3                |      |       |      |            | 7                   | 3    | 0     | 0    | 10         |                  |      |       |      |            |                     |      |       |      |            | 553        |
| 07:15  | 0                | 429  | 2     | 0    | 431        | 2                   | 0    | 1     | 0    | 3          | 3                |      |       |      |            |                     |      |       |      |            |            |
| Total Volume   | 3                | 1772 | 9     | 0    | 1784       | 17                  | 10   | 2     | 0    | 29         | 4                | 357  | 0     | 0    | 361        | 4                   | 1    | 44    | 0    | 49         | 2223       |
| % App. Total   | 0.2              | 99.3 | 0.5   | 0    |            | 58.6                | 34.5 | 6.9   | 0    |            | 1.1              | 98.9 | 0     | 0    |            | 8.2                 | 2    | 89.8  | 0    |            |            |
| PHF  | .250             | .869 | .563  | .000 | .869       | .607                | .417 | .500  | .000 | .725       | .333             | .875 | .000  | .000 | .885       | .333                | .250 | .786  | .000 | .681       | .913       |

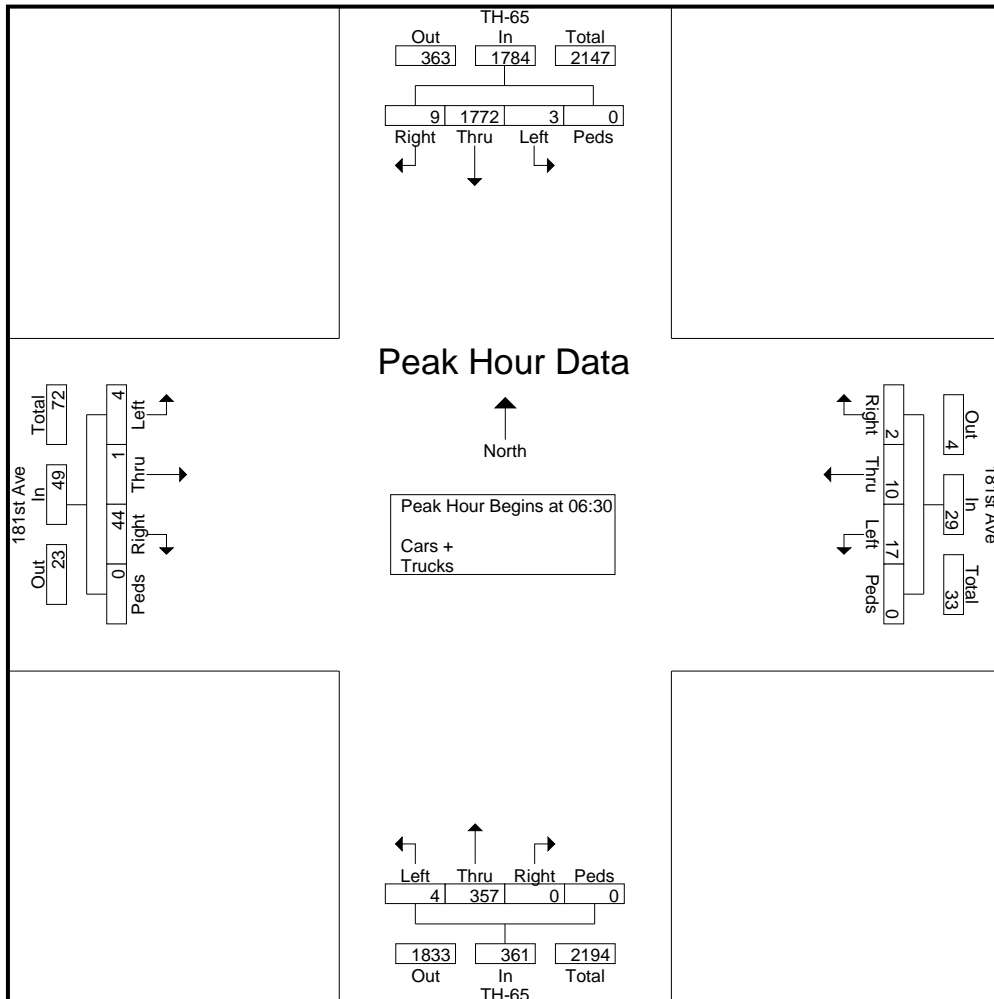

# MINNESOTA DEPARTMENT OF TRANSPORTATION

## TRAFFIC DATA COLLECTION - Metro

TH-65 at 181st Ave  
 Ref.Pt.: 022+00.392  
 Video by XY  
**TURN MOVEMENT COUNT**

File Name : TH-65 at 181st Ave 2017  
 Site Code :  
 Start Date : 2/1/2017  
 Page No : 4

| Start Time   | TH-65 Southbound |      |       |      |            | 181st Ave Westbound |      |       |      |            | TH-65 Northbound |      |       |      |            | 181st Ave Eastbound |      |       |      |            | Int. Total |
|--|------------------|------|-------|------|------------|---------------------|------|-------|------|------------|------------------|------|-------|------|------------|---------------------|------|-------|------|------------|------------|
|  | Left             | Thru | Right | Peds | App. Total | Left                | Thru | Right | Peds | App. Total | Left             | Thru | Right | Peds | App. Total | Left                | Thru | Right | Peds | App. Total |            |
| Peak Hour Analysis From 12:00 to 17:45 - Peak 1 of 1 |                  |      |       |      |            |                     |      |       |      |            |                  |      |       |      |            |                     |      |       |      |            |            |
| Peak Hour for Entire Intersection Begins at 16:45    |                  |      |       |      |            |                     |      |       |      |            |                  |      |       |      |            |                     |      |       |      |            |            |
| 16:45  | 2                |      |       |      |            | 2                   | 4    | 0     | 0    | 6          | 28               | 544  | 2     | 0    | 574        | 1                   | 2    | 3     | 0    | 6          | 795        |
| 17:00  | 0                | 201  | 8     | 0    | 209        | 7                   | 3    | 0     | 0    | 10         | 23               | 460  | 5     | 0    | 488        | 3                   | 4    | 8     | 0    | 15         | 733        |
| 17:30  | 1                | 211  | 3     | 0    | 215        | 1                   | 1    | 0     | 0    | 2          | 23               | 542  | 4     | 0    | 569        | 3                   | 2    | 10    |      |            | 801        |
| Total Volume   | 3                | 829  | 24    | 0    | 856        | 12                  | 8    | 0     | 0    | 20         | 94               | 2040 | 15    | 0    | 2149       | 8                   | 10   | 29    | 0    | 47         | 3072       |
| % App. Total   |                  |      |       |      |            |                     |      |       |      |            |                  |      |       |      |            |                     |      |       |      |            |            |
| PHF  | .375             | .978 | .750  | .000 | .973       | .429                | .500 | .000  | .000 | .500       | .839             | .938 | .750  | .000 | .936       | .667                | .625 | .725  | .000 | .783       | .959       |

