

Alliant Engineering Inc Minneapolis, MN 55415

TH-65 at 237th Ave NE/ CSAH-24
Ref.Pt.: 029.389
data by Alliant Engineering Inc
TURN MOVEMENT COUNT

File Name : TH-65 at 237th Ave NE 2009
Site Code : 00000024
Start Date : 1/20/2009
Page No : 1

Groups Printed- Unshifted

Start Time	TH-65 Southbound				237th Ave NE Westbound				TH-65 Northbound				237th Ave NE Eastbound				Int. Total
	Left	Thru	Right	Peds	Left	Thru	Right	Peds	Left	Thru	Right	Peds	Left	Thru	Right	Peds	
06:00	6	255	5	0	23	2	7	0	3	21	0	0	4	5	23	0	354
06:15	10	276	4	0	21	5	3	0	0	37	1	0	4	10	15	0	386
06:30	10	224	5	0	17	8	6	0	4	48	0	0	2	9	20	0	353
06:45	11	232	15	0	15	16	5	0	2	48	3	0	8	7	18	0	380
Total	37	987	29	0	76	31	21	0	9	154	4	0	18	31	76	0	1473
07:00	10	219	5	0	13	10	2	0	1	66	2	0	10	12	19	0	369
07:15	6	221	4	0	27	8	13	0	5	74	1	0	3	13	13	0	388
07:30	7	198	3	0	16	10	17	0	3	99	6	0	8	10	10	0	387
07:45	3	178	7	0	6	4	9	0	3	69	5	0	8	8	10	0	310
Total	26	816	19	0	62	32	41	0	12	308	14	0	29	43	52	0	1454
08:00	9	140	3	0	17	3	8	0	2	74	6	0	7	3	4	0	276
08:15	5	141	5	0	11	6	3	0	1	61	2	0	2	4	8	0	249
08:30	6	130	5	0	12	5	6	0	2	53	2	0	1	6	9	0	237
08:45	4	120	4	0	7	2	4	0	6	51	8	0	7	4	7	0	224
Total	24	531	17	0	47	16	21	0	11	239	18	0	17	17	28	0	986
09:00	11	95	3	0	11	3	5	0	3	55	8	0	6	1	8	0	209
09:15	8	121	4	0	5	5	6	0	6	50	2	0	3	2	6	0	218
*** BREAK ***																	
Total	19	216	7	0	16	8	11	0	9	105	10	0	9	3	14	0	427
*** BREAK ***																	
10:30	7	83	6	0	5	1	9	0	2	59	6	0	3	7	5	0	193
10:45	2	68	4	0	5	4	3	0	1	54	5	0	8	1	6	0	161
Total	9	151	10	0	10	5	12	0	3	113	11	0	11	8	11	0	354
11:00	7	73	1	0	5	2	6	0	1	45	9	0	4	2	5	0	160
11:15	4	86	5	0	7	4	8	0	3	55	2	0	3	2	6	0	185
11:30	5	74	8	0	4	1	10	0	2	70	4	0	6	3	6	0	193
11:45	6	76	4	0	5	5	7	0	2	65	4	0	5	5	4	0	188
Total	22	309	18	0	21	12	31	0	8	235	19	0	18	12	21	0	726
12:00	9	68	2	0	12	8	5	0	1	66	8	0	8	12	6	0	205
12:15	13	90	1	0	9	7	14	0	5	72	7	0	3	2	8	0	231
12:30	10	76	6	0	2	3	12	0	5	77	6	0	8	6	4	0	215
12:45	6	75	4	0	9	7	7	0	4	90	7	0	9	11	6	0	235
Total	38	309	13	0	32	25	38	0	15	305	28	0	28	31	24	0	886
13:00	5	56	6	0	7	3	3	0	6	74	4	0	2	8	8	0	182
13:15	7	90	3	0	3	9	13	0	5	79	10	0	6	3	6	0	234
*** BREAK ***																	
Total	12	146	9	0	10	12	16	0	11	153	14	0	8	11	14	0	416
*** BREAK ***																	
14:30	12	77	10	0	3	7	9	0	6	118	6	0	5	7	4	0	264
14:45	8	76	0	0	3	6	13	0	2	155	7	0	9	10	7	0	296
Total	20	153	10	0	6	13	22	0	8	273	13	0	14	17	11	0	560
15:00	10	89	11	0	6	9	7	0	11	134	18	0	5	10	7	0	317
15:15	7	94	8	0	5	6	12	0	9	188	15	0	6	10	4	0	364
15:30	11	74	10	0	5	7	13	0	11	220	17	0	12	10	8	0	398
15:45	6	112	9	0	3	10	13	0	16	199	11	0	12	9	5	0	405
Total	34	369	38	0	19	32	45	0	47	741	61	0	35	39	24	0	1484

Alliant Engineering Inc Minneapolis, MN 55415

TH-65 at 237th Ave NE/ CSAH-24
 Ref.Pt.: 029.389
 data by Alliant Engineering Inc
 TURN MOVEMENT COUNT

File Name : TH-65 at 237th Ave NE 2009
 Site Code : 00000024
 Start Date : 1/20/2009
 Page No : 2

Groups Printed- Unshifted

Start Time	TH-65 Southbound				237th Ave NE Westbound				TH-65 Northbound				237th Ave NE Eastbound				Int. Total
	Left	Thru	Right	Peds	Left	Thru	Right	Peds	Left	Thru	Right	Peds	Left	Thru	Right	Peds	
16:00	5	93	11	0	5	10	17	1	12	275	17	0	8	9	3	0	466
16:15	13	101	11	0	10	12	17	0	14	268	20	0	17	8	7	0	498
16:30	11	85	11	0	6	17	25	0	13	270	22	0	12	18	9	0	499
16:45	11	113	9	0	6	14	22	0	15	257	26	0	13	9	4	0	499
Total	40	392	42	0	27	53	81	1	54	1070	85	0	50	44	23	0	1962
17:00	15	104	9	0	9	21	11	0	16	247	26	0	14	10	7	0	489
17:15	10	101	12	0	9	23	21	1	16	312	17	0	10	12	6	0	550
17:30	15	81	13	0	7	13	12	0	12	227	16	0	16	11	6	0	429
17:45	6	83	7	0	4	14	10	0	12	186	23	0	6	10	9	0	370
Total	46	369	41	0	29	71	54	1	56	972	82	0	46	43	28	0	1838
Grand Total	327	4748	253	0	355	310	393	2	243	4668	359	0	283	299	326	0	12566
Apprch %	6.1	89.1	4.7	0	33.5	29.2	37.1	0.2	4.6	88.6	6.8	0	31.2	32.9	35.9	0	
Total %	2.6	37.8	2	0	2.8	2.5	3.1	0	1.9	37.1	2.9	0	2.3	2.4	2.6	0	

Alliant Engineering Inc Minneapolis, MN 55415

TH-65 at 237th Ave NE/ CSAH-24
 Ref.Pt.: 029.389
 data by Alliant Engineering Inc
 TURN MOVEMENT COUNT

File Name : TH-65 at 237th Ave NE 2009
 Site Code : 00000024
 Start Date : 1/20/2009
 Page No : 3

Start Time	TH-65 Southbound					237th Ave NE Westbound					TH-65 Northbound					237th Ave NE Eastbound					Int. Total
	Left	Thru	Right	Peds	App. Total	Left	Thru	Right	Peds	App. Total	Left	Thru	Right	Peds	App. Total	Left	Thru	Right	Peds	App. Total	
Peak Hour Analysis From 06:00 to 09:00 - Peak 1 of 1																					
Peak Hour for Entire Intersection Begins at 06:45																					
06:45	11	232	15	0	258	15	16	5	0	36	2	48	3	0	53	8	7	18	0	33	380
07:00	10	219	5	0	234	13	10	2	0	25	1	66	2	0	69	10	12	19	0	41	369
07:15	6	221	4	0	231	27	8	13	0	48	5	74	1	0	80	3	13	13	0	29	388
07:30	7	198	3	0	208	16	10	17	0	43	3	99	6	0	108	8	10	10	0	28	387
Total Volume	34	870	27	0	931	71	44	37	0	152	11	287	12	0	310	29	42	60	0	131	1524
% App. Total	3.7	93.4	2.9	0		46.7	28.9	24.3	0		3.5	92.6	3.9	0		22.1	32.1	45.8	0		
PHF	.773	.938	.450	.000	.902	.657	.688	.544	.000	.792	.550	.725	.500	.000	.718	.725	.808	.789	.000	.799	.982

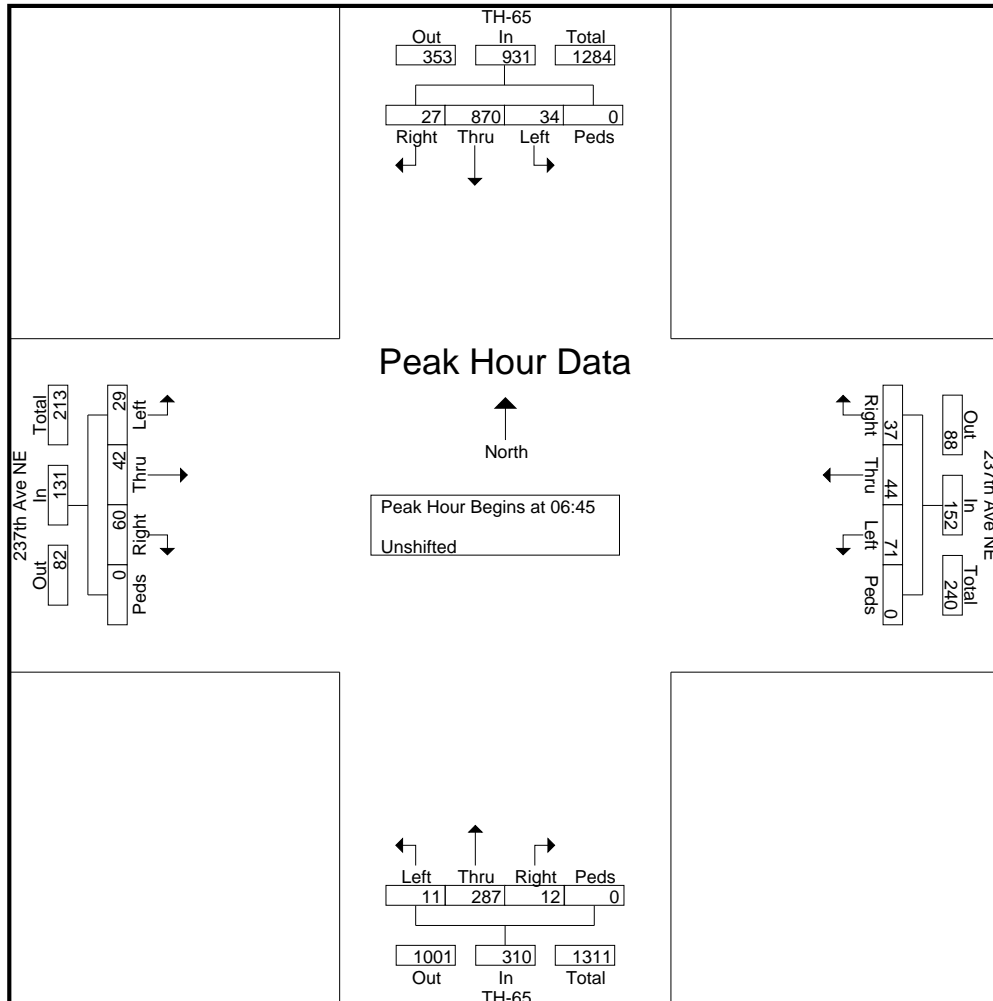

Alliant Engineering Inc Minneapolis, MN 55415

TH-65 at 237th Ave NE/ CSAH-24
Ref.Pt.: 029.389
data by Alliant Engineering Inc
TURN MOVEMENT COUNT

File Name : TH-65 at 237th Ave NE 2009
Site Code : 00000024
Start Date : 1/20/2009
Page No : 4

Start Time	TH-65 Southbound					237th Ave NE Westbound					TH-65 Northbound					237th Ave NE Eastbound					Int. Total
	Left	Thru	Right	Peds	App. Total	Left	Thru	Right	Peds	App. Total	Left	Thru	Right	Peds	App. Total	Left	Thru	Right	Peds	App. Total	
Peak Hour Analysis From 15:00 to 17:45 - Peak 1 of 1																					
Peak Hour for Entire Intersection Begins at 16:30																					
16:30	11	85	11	0	107	6	17	25	0	48	13	270	22	0	305	12	18	9	0	39	499
16:45	11	113	9	0	133	6	14	22	0	42	15	257	26	0	298	13	9	4	0	26	499
17:00	15	104	9	0	128	9	21	11	0	41	16	247	26	0	289	14	10	7	0	31	489
17:15	10	101	12	0	123	9	23	21	1	54	16	312	17	0	345	10	12	6	0	28	550
Total Volume	47	403	41	0	491	30	75	79	1	185	60	1086	91	0	1237	49	49	26	0	124	2037
% App. Total	9.6	82.1	8.4	0		16.2	40.5	42.7	0.5		4.9	87.8	7.4	0		39.5	39.5	21	0		
PHF	.783	.892	.854	.000	.923	.833	.815	.790	.250	.856	.938	.870	.875	.000	.896	.875	.681	.722	.000	.795	.926

