

# Alliant Engineering Inc Minneapolis, MN 55415

TH-7 at Christmas Lake Rd.  
Ref.Pt.: 183.627  
Alliant Engineering Inc  
TURN MOVEMENT COUNT

File Name : 3\_TH 7 at Christmas Lake Rd\_020211  
Site Code : 00000003  
Start Date : 2/2/2011  
Page No : 1

### Groups Printed- Unshifted - Bank 1

Start Time	Christmas Lake Rd Southbound				TH-7 Westbound				Christmas Lake Rd Northbound				TH-7 Eastbound				Int. Total
	Left	Thru	Right	Peds	Left	Thru	Right	Peds	Left	Thru	Right	Peds	Left	Thru	Right	Peds	
06:00	3	1	1	0	3	59	0	0	0	0	3	0	2	197	3	0	272
06:15	6	0	3	0	1	87	1	1	0	1	10	0	0	246	3	0	359
06:30	3	0	1	0	0	105	1	0	2	0	9	0	1	356	0	0	478
06:45	6	0	3	0	2	121	2	0	4	0	11	0	3	402	2	0	556
Total	18	1	8	0	6	372	4	1	6	1	33	0	6	1201	8	0	1665
07:00	13	0	1	0	0	124	2	0	1	0	15	0	6	494	2	0	658
07:15	17	0	0	0	5	182	2	0	3	2	8	0	16	574	9	0	818
07:30	13	1	3	0	1	213	8	0	6	1	18	0	14	718	3	0	999
07:45	18	3	7	0	1	220	5	0	3	0	10	0	9	552	1	0	829
Total	61	4	11	0	7	739	17	0	13	3	51	0	45	2338	15	0	3304
08:00	15	2	5	0	3	207	8	1	2	1	12	0	14	409	3	0	682
08:15	17	1	5	0	5	161	11	0	4	2	13	0	9	394	5	0	627
08:30	18	1	3	0	6	143	7	0	2	0	14	0	12	343	2	0	551
08:45	15	1	5	0	1	236	4	0	3	2	12	0	6	311	3	0	599
Total	65	5	18	0	15	747	30	1	11	5	51	0	41	1457	13	0	2459
09:00	13	2	13	0	4	207	5	0	5	0	9	0	9	310	2	0	579
09:15	7	4	4	0	3	182	8	0	4	1	8	0	3	237	5	0	466
*** BREAK ***																	
Total	20	6	17	0	7	389	13	0	9	1	17	0	12	547	7	0	1045
*** BREAK ***																	
10:30	10	0	6	1	2	157	6	0	1	1	8	0	3	148	7	0	350
10:45	16	0	1	0	4	151	7	0	4	0	8	0	10	189	6	0	396
Total	26	0	7	1	6	308	13	0	5	1	16	0	13	337	13	0	746
11:00	8	2	1	0	5	150	4	0	3	1	5	0	7	186	5	0	377
11:15	23	3	3	0	1	184	6	1	3	1	6	0	17	187	7	0	442
11:30	22	1	8	0	6	181	10	0	2	0	5	0	8	201	4	0	448
11:45	11	1	5	0	3	171	9	0	4	0	6	0	10	173	5	0	398
Total	64	7	17	0	15	686	29	1	12	2	22	0	42	747	21	0	1665
12:00	21	0	12	0	8	151	15	0	1	0	5	0	8	173	3	0	397
12:15	17	0	5	0	5	179	9	0	2	1	11	0	10	178	4	0	421
12:30	20	0	8	0	11	215	10	0	2	1	4	0	8	178	7	0	464
12:45	9	1	7	0	6	213	6	0	3	0	8	0	5	176	7	0	441
Total	67	1	32	0	30	758	40	0	8	2	28	0	31	705	21	0	1723
13:00	23	1	7	0	8	196	5	0	1	0	9	0	10	205	8	0	473
13:15	18	0	4	0	3	214	6	0	2	0	6	0	12	166	6	0	437
*** BREAK ***																	
Total	41	1	11	0	11	410	11	0	3	0	15	0	22	371	14	0	910
*** BREAK ***																	
14:30	17	1	7	1	7	267	10	0	1	0	9	0	12	237	6	0	575
14:45	11	4	4	0	9	341	11	0	5	0	14	0	10	232	5	0	646
Total	28	5	11	1	16	608	21	0	6	0	23	0	22	469	11	0	1221
15:00	20	4	8	0	8	324	15	0	9	2	6	0	8	212	4	0	620
15:15	14	2	7	0	12	356	10	2	6	1	6	0	9	194	4	0	623
15:30	13	3	8	0	7	369	8	0	4	1	9	0	16	239	1	0	678
15:45	8	0	11	0	6	387	10	0	1	0	6	0	9	227	4	0	669
Total	55	9	34	0	33	1436	43	2	20	4	27	0	42	872	13	0	2590

# Alliant Engineering Inc Minneapolis, MN 55415

TH-7 at Christmas Lake Rd.  
Ref.Pt.: 183.627  
Alliant Engineering Inc  
TURN MOVEMENT COUNT

File Name : 3\_TH 7 at Christmas Lake Rd\_020211  
Site Code : 00000003  
Start Date : 2/2/2011  
Page No : 2

### Groups Printed- Unshifted - Bank 1

Start Time	Christmas Lake Rd Southbound				TH-7 Westbound				Christmas Lake Rd Northbound				TH-7 Eastbound				Int. Total
	Left	Thru	Right	Peds	Left	Thru	Right	Peds	Left	Thru	Right	Peds	Left	Thru	Right	Peds	
16:00	18	1	7	0	5	325	9	0	4	1	6	0	13	239	10	0	638
16:15	5	1	3	0	6	456	10	0	6	0	11	0	4	252	10	0	764
16:30	16	3	9	0	7	449	11	0	3	1	7	0	16	232	3	0	757
16:45	11	0	8	0	8	494	19	3	2	2	7	0	6	248	9	0	817
Total	50	5	27	0	26	1724	49	3	15	4	31	0	39	971	32	0	2976
17:00	12	4	7	0	12	433	11	0	2	1	6	0	11	249	9	0	757
17:15	11	1	11	0	16	546	16	0	3	0	9	0	16	258	5	0	892
17:30	16	2	11	0	9	504	8	0	7	1	8	0	10	234	14	0	824
17:45	7	0	4	0	18	507	11	3	2	2	1	0	12	244	5	0	816
Total	46	7	33	0	55	1990	46	3	14	4	24	0	49	985	33	0	3289
Grand Total	541	51	226	2	227	10167	316	11	122	27	338	0	364	11000	201	0	23593
Apprch %	66	6.2	27.6	0.2	2.1	94.8	2.9	0.1	25.1	5.5	69.4	0	3.1	95.1	1.7	0	
Total %	2.3	0.2	1	0	1	43.1	1.3	0	0.5	0.1	1.4	0	1.5	46.6	0.9	0	
Unshifted	526	48	214	2	219	9861	306	11	120	25	331	0	363	10763	192	0	22981
% Unshifted	97.2	94.1	94.7	100	96.5	97	96.8	100	98.4	92.6	97.9	0	99.7	97.8	95.5	0	97.4
Bank 1	15	3	12	0	8	306	10	0	2	2	7	0	1	237	9	0	612
% Bank 1	2.8	5.9	5.3	0	3.5	3	3.2	0	1.6	7.4	2.1	0	0.3	2.2	4.5	0	2.6

# Alliant Engineering Inc Minneapolis, MN 55415

TH-7 at Christmas Lake Rd.  
Ref.Pt.: 183.627  
Alliant Engineering Inc  
TURN MOVEMENT COUNT

File Name : 3\_TH 7 at Christmas Lake Rd\_020211  
Site Code : 00000003  
Start Date : 2/2/2011  
Page No : 3

Start Time	Christmas Lake Rd Southbound					TH-7 Westbound					Christmas Lake Rd Northbound					TH-7 Eastbound					Int. Total
	Left	Thru	Right	Peds	App. Total	Left	Thru	Right	Peds	App. Total	Left	Thru	Right	Peds	App. Total	Left	Thru	Right	Peds	App. Total	
Peak Hour Analysis From 06:00 to 09:15 - Peak 1 of 1																					
Peak Hour for Entire Intersection Begins at 07:15																					
07:15	17	0	0	0	17	5	182	2	0	189	3	2	8	0	13	16	574	9	0	599	818
07:30	13	1	3	0	17	1	213	8	0	222	6	1	18	0	25	14	718	3	0	735	999
07:45	18	3	7	0	28	1	220	5	0	226	3	0	10	0	13	9	552	1	0	562	829
08:00	15	2	5	0	22	3	207	8	1	219	2	1	12	0	15	14	409	3	0	426	682
Total Volume	63	6	15	0	84	10	822	23	1	856	14	4	48	0	66	53	2253	16	0	2322	3328
% App. Total	75	7.1	17.9	0		1.2	96	2.7	0.1		21.2	6.1	72.7	0		2.3	97	0.7	0		
PHF	.875	.500	.536	.000	.750	.500	.934	.719	.250	.947	.583	.500	.667	.000	.660	.828	.784	.444	.000	.790	.833

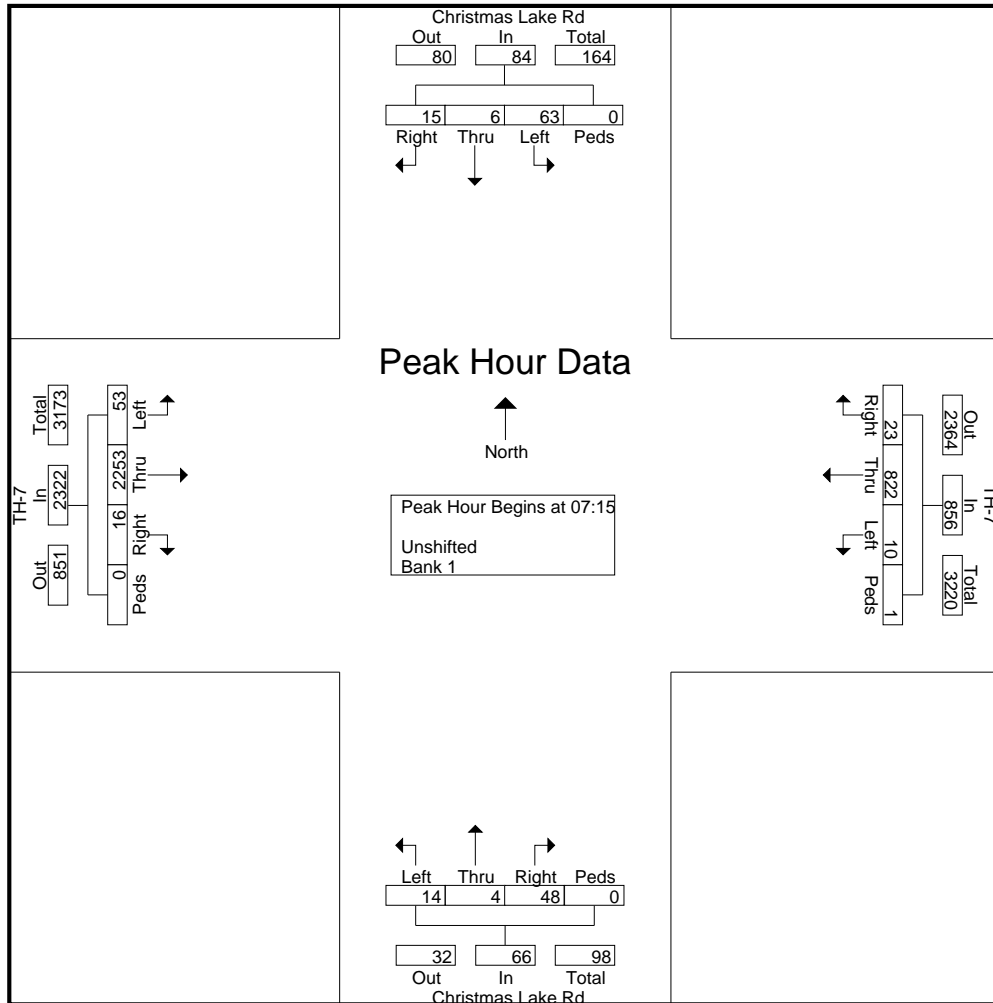

# Alliant Engineering Inc Minneapolis, MN 55415

TH-7 at Christmas Lake Rd.  
Ref.Pt.: 183.627  
Alliant Engineering Inc  
TURN MOVEMENT COUNT

File Name : 3\_TH 7 at Christmas Lake Rd\_020211  
Site Code : 00000003  
Start Date : 2/2/2011  
Page No : 4

Start Time	Christmas Lake Rd Southbound					TH-7 Westbound					Christmas Lake Rd Northbound					TH-7 Eastbound					Int. Total
	Left	Thru	Right	Peds	App. Total	Left	Thru	Right	Peds	App. Total	Left	Thru	Right	Peds	App. Total	Left	Thru	Right	Peds	App. Total	
Peak Hour Analysis From 14:30 to 17:45 - Peak 1 of 1																					
Peak Hour for Entire Intersection Begins at 16:45																					
16:45	11	0	8	0	19	8	494	19	3	524	2	2	7	0	11	6	248	9	0	263	817
17:00	12	4	7	0	23	12	433	11	0	456	2	1	6	0	9	11	249	9	0	269	757
17:15	11	1	11	0	23	16	546	16	0	578	3	0	9	0	12	16	258	5	0	279	892
17:30	16	2	11	0	29	9	504	8	0	521	7	1	8	0	16	10	234	14	0	258	824
Total Volume	50	7	37	0	94	45	1977	54	3	2079	14	4	30	0	48	43	989	37	0	1069	3290
% App. Total	53.2	7.4	39.4	0		2.2	95.1	2.6	0.1		29.2	8.3	62.5	0		4	92.5	3.5	0		
PHF	.781	.438	.841	.000	.810	.703	.905	.711	.250	.899	.500	.500	.833	.000	.750	.672	.958	.661	.000	.958	.922

