

Alliant Engineering Inc Minneapolis, MN 55415

Blake Rd N at Cambridge Street
Ref.Pt.
Alliant Engineering Inc
TURN MOVEMENT COUNT

File Name : 20_Blake Rd at Cambridge St_010611
Site Code : 00000020
Start Date : 1/6/2011
Page No : 1

Groups Printed- Unshifted - Bank 1

Start Time	Blake Rd N / CSAH-20 Southbound				Cambridge St Westbound				Blake Rd N / CSAH-20 Northbound				Cambridge St Eastbound				Int. Total
	Left	Thru	Rght	Peds	Left	Thru	Rght	Peds	Left	Thru	Rght	Peds	Left	Thru	Rght	Peds	
06:00	0	25	2	1	2	0	1	0	2	18	0	1	11	2	0	0	65
06:15	1	28	2	0	2	0	1	0	1	25	1	2	14	0	3	0	80
06:30	4	41	1	0	0	0	11	0	4	42	1	1	16	0	3	0	124
06:45	1	61	0	1	5	2	6	1	3	43	2	1	14	0	2	1	143
Total	6	155	5	2	9	2	19	1	10	128	4	5	55	2	8	1	412
07:00	0	65	3	0	4	0	8	1	2	64	0	0	12	0	8	0	167
07:15	4	79	4	0	4	3	5	0	2	49	1	0	15	3	8	2	179
07:30	4	84	5	0	7	1	9	0	1	78	3	0	30	4	4	0	230
07:45	2	92	1	0	9	0	6	0	4	62	2	0	15	4	5	2	204
Total	10	320	13	0	24	4	28	1	9	253	6	0	72	11	25	4	780
08:00	2	105	5	0	5	1	10	2	1	79	1	1	21	3	6	5	247
08:15	0	83	6	1	5	1	5	0	6	76	6	4	28	2	5	0	228
08:30	3	75	7	0	6	1	11	1	8	91	1	0	37	1	6	0	248
08:45	3	61	4	1	6	3	3	0	5	88	4	3	36	1	5	0	223
Total	8	324	22	2	22	6	29	3	20	334	12	8	122	7	22	5	946
09:00	4	51	9	1	7	3	3	0	8	56	2	2	26	3	5	0	180
09:15	8	62	4	1	3	3	3	0	3	67	3	1	39	2	4	1	204
*** BREAK ***																	
Total	12	113	13	2	10	6	6	0	11	123	5	3	65	5	9	1	384
*** BREAK ***																	
10:30	3	71	5	0	2	2	4	0	6	74	5	3	17	1	6	1	200
10:45	5	80	4	1	3	0	5	1	9	75	3	2	25	2	5	1	221
Total	8	151	9	1	5	2	9	1	15	149	8	5	42	3	11	2	421
11:00	5	72	11	0	7	2	3	0	13	78	7	0	18	3	9	0	228
11:15	5	66	16	3	10	4	2	1	16	98	5	2	30	1	12	2	273
11:30	7	97	16	0	6	1	7	0	18	99	7	7	37	2	12	1	317
11:45	7	105	25	1	5	7	4	2	9	113	4	4	44	0	18	1	349
Total	24	340	68	4	28	14	16	3	56	388	23	13	129	6	51	4	1167
12:00	5	106	27	0	5	3	2	0	22	113	7	0	34	4	14	1	343
12:15	10	98	26	0	4	2	5	0	18	115	3	3	50	1	19	0	354
12:30	3	108	24	0	5	2	3	1	17	92	5	2	54	6	22	1	345
12:45	6	111	8	0	2	1	8	1	22	100	6	4	48	3	20	4	344
Total	24	423	85	0	16	8	18	2	79	420	21	9	186	14	75	6	1386
13:00	8	98	16	4	2	4	5	0	19	105	4	2	33	3	16	1	320
13:15	3	79	18	0	6	5	2	1	12	109	6	3	47	3	20	0	314
*** BREAK ***																	
Total	11	177	34	4	8	9	7	1	31	214	10	5	80	6	36	1	634
*** BREAK ***																	
14:30	8	126	7	1	5	4	4	0	18	99	2	0	43	3	17	1	338
14:45	10	100	16	3	5	3	4	1	7	122	3	6	45	3	8	6	342
Total	18	226	23	4	10	7	8	1	25	221	5	6	88	6	25	7	680
15:00	7	98	15	1	6	3	1	3	20	116	2	1	32	6	10	3	324
15:15	8	132	17	1	5	4	1	2	15	86	0	1	33	8	20	3	336
15:30	8	110	8	0	5	3	2	0	9	143	2	2	29	2	12	3	338
15:45	9	102	11	0	6	2	4	1	13	148	2	0	41	2	14	1	356
Total	32	442	51	2	22	12	8	6	57	493	6	4	135	18	56	10	1354

Alliant Engineering Inc Minneapolis, MN 55415

Blake Rd N at Cambridge Street
Ref.Pt.
Alliant Engineering Inc
TURN MOVEMENT COUNT

File Name : 20_Blake Rd at Cambridge St_010611
Site Code : 00000020
Start Date : 1/6/2011
Page No : 2

Groups Printed- Unshifted - Bank 1

Start Time	Blake Rd N / CSAH-20 Southbound				Cambridge St Westbound				Blake Rd N / CSAH-20 Northbound				Cambridge St Eastbound				Int. Total
	Left	Thru	Rght	Peds	Left	Thru	Rght	Peds	Left	Thru	Rght	Peds	Left	Thru	Rght	Peds	
16:00	6	106	14	1	5	2	4	0	11	126	19	1	35	3	20	1	354
16:15	7	129	27	0	1	7	6	0	14	154	4	0	40	8	23	3	423
16:30	9	125	14	3	5	3	4	0	20	185	2	4	28	3	16	1	422
16:45	3	134	23	0	4	2	4	0	16	131	9	4	37	5	11	2	385
Total	25	494	78	4	15	14	18	0	61	596	34	9	140	19	70	7	1584
17:00	11	112	27	0	3	4	2	1	21	203	7	1	35	5	12	0	444
17:15	8	123	21	1	2	3	4	1	12	185	10	1	50	5	14	3	443
17:30	5	128	13	3	6	4	5	0	17	185	4	0	45	6	21	2	444
17:45	11	145	40	0	6	2	5	0	13	155	5	0	39	2	11	3	437
Total	35	508	101	4	17	13	16	2	63	728	26	2	169	18	58	8	1768
Grand Total	213	3673	502	29	186	97	182	21	437	4047	160	69	1283	115	446	56	11516
Apprch %	4.8	83.2	11.4	0.7	38.3	20	37.4	4.3	9.3	85.9	3.4	1.5	67.5	6.1	23.5	2.9	
Total %	1.8	31.9	4.4	0.3	1.6	0.8	1.6	0.2	3.8	35.1	1.4	0.6	11.1	1	3.9	0.5	
Unshifted	207	3570	483	29	181	93	177	21	426	3957	155	69	1238	113	427	56	11202
% Unshifted	97.2	97.2	96.2	100	97.3	95.9	97.3	100	97.5	97.8	96.9	100	96.5	98.3	95.7	100	97.3
Bank 1	6	103	19	0	5	4	5	0	11	90	5	0	45	2	19	0	314
% Bank 1	2.8	2.8	3.8	0	2.7	4.1	2.7	0	2.5	2.2	3.1	0	3.5	1.7	4.3	0	2.7

Alliant Engineering Inc Minneapolis, MN 55415

Blake Rd N at Cambridge Street
Ref.Pt.
Alliant Engineering Inc
TURN MOVEMENT COUNT

File Name : 20_Blake Rd at Cambridge St_010611
Site Code : 00000020
Start Date : 1/6/2011
Page No : 3

Start Time	Blake Rd N / CSAH-20 Southbound					Cambridge St Westbound					Blake Rd N / CSAH-20 Northbound					Cambridge St Eastbound					Int. Total
	Left	Thru	Rght	Peds	App. Total	Left	Thru	Rght	Peds	App. Total	Left	Thru	Rght	Peds	App. Total	Left	Thru	Rght	Peds	App. Total	
Peak Hour Analysis From 06:00 to 09:15 - Peak 1 of 1																					
Peak Hour for Entire Intersection Begins at 08:00																					
08:00	2	105	5	0	112	5	1	10	2	18	1	79	1	1	82	21	3	6	5	35	247
08:15	0	83	6	1	90	5	1	5	0	11	6	76	6	4	92	28	2	5	0	35	228
08:30	3	75	7	0	85	6	1	11	1	19	8	91	1	0	100	37	1	6	0	44	248
08:45	3	61	4	1	69	6	3	3	0	12	5	88	4	3	100	36	1	5	0	42	223
Total Volume	8	324	22	2	356	22	6	29	3	60	20	334	12	8	374	122	7	22	5	156	946
% App. Total	2.2	91	6.2	0.6		36.7	10	48.3	5		5.3	89.3	3.2	2.1		78.2	4.5	14.1	3.2		
PHF	.667	.771	.786	.500	.795	.917	.500	.659	.375	.789	.625	.918	.500	.500	.935	.824	.583	.917	.250	.886	.954

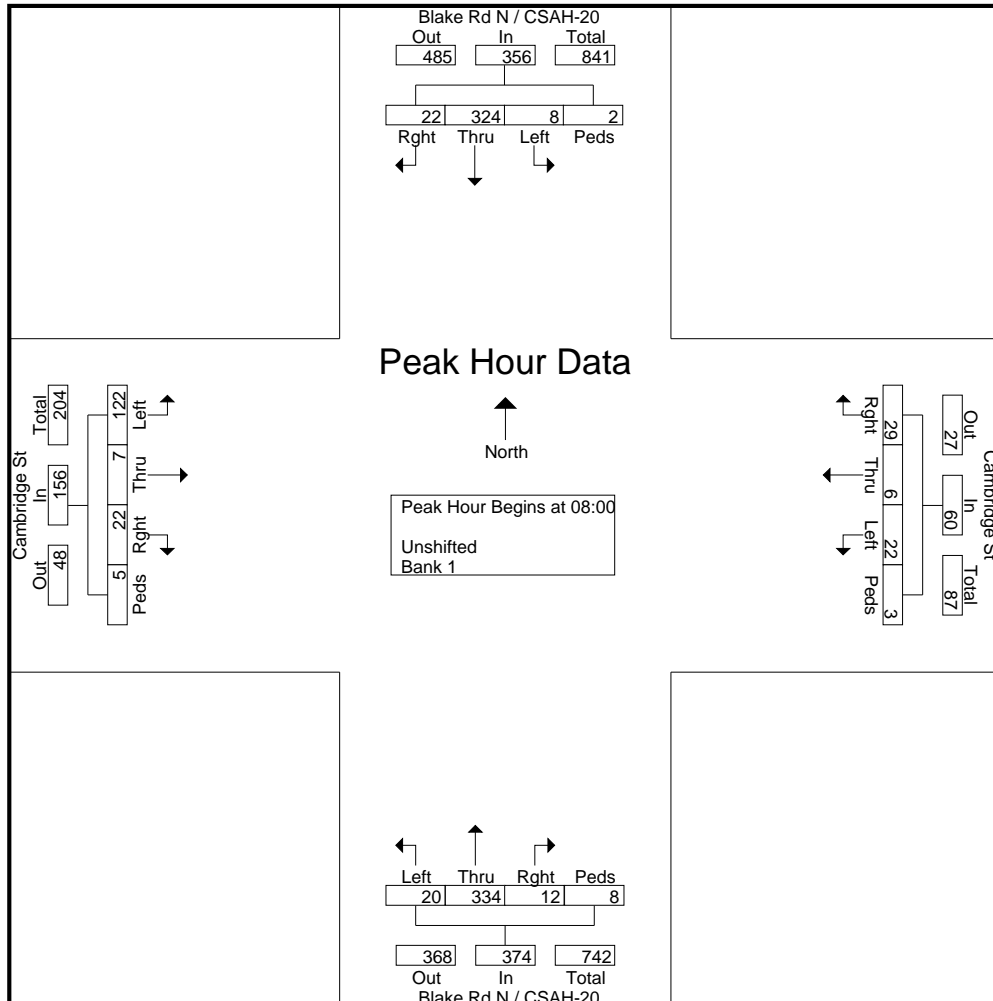

Alliant Engineering Inc Minneapolis, MN 55415

Blake Rd N at Cambridge Street
Ref.Pt.
Alliant Engineering Inc
TURN MOVEMENT COUNT

File Name : 20_Blake Rd at Cambridge St_010611
Site Code : 00000020
Start Date : 1/6/2011
Page No : 4

Start Time	Blake Rd N / CSAH-20 Southbound					Cambridge St Westbound					Blake Rd N / CSAH-20 Northbound					Cambridge St Eastbound					Int. Total
	Left	Thru	Rght	Peds	App. Total	Left	Thru	Rght	Peds	App. Total	Left	Thru	Rght	Peds	App. Total	Left	Thru	Rght	Peds	App. Total	
Peak Hour Analysis From 14:30 to 17:45 - Peak 1 of 1																					
Peak Hour for Entire Intersection Begins at 17:00																					
17:00	11	112	27	0	150	3	4	2	1	10	21	203	7	1	232	35	5	12	0	52	444
17:15	8	123	21	1	153	2	3	4	1	10	12	185	10	1	208	50	5	14	3	72	443
17:30	5	128	13	3	149	6	4	5	0	15	17	185	4	0	206	45	6	21	2	74	444
17:45	11	145	40	0	196	6	2	5	0	13	13	155	5	0	173	39	2	11	3	55	437
Total Volume	35	508	101	4	648	17	13	16	2	48	63	728	26	2	819	169	18	58	8	253	1768
% App. Total	5.4	78.4	15.6	0.6		35.4	27.1	33.3	4.2		7.7	88.9	3.2	0.2		66.8	7.1	22.9	3.2		
PHF	.795	.876	.631	.333	.827	.708	.813	.800	.500	.800	.750	.897	.650	.500	.883	.845	.750	.690	.667	.855	.995

