



MINNESOTA DEPT OF TRANSPORTATION

TRAFFIC DATA COLLECTION - METRO

TH-8 at Lincoln Rd / CSAH-14
 Ref.Pt.: 011.136 LINDSTROM
 JAMAR # 631 CP
 TURN MOVEMENT COUNT

File Name : TH-8 at Lincoln Rd CSAH-14 2010
 Site Code : 00000000
 Start Date : 5/26/2010
 Page No : 1

Groups Printed- Cars & Trucks

Start Time	Lincoln Rd / CSAH-14 Southbound				TH-8 Westbound				Lincoln Rd Northbound				TH-8 Eastbound				Int. Total
	Left	Thru	Right	Peds	Left	Thru	Right	Peds	Left	Thru	Right	Peds	Left	Thru	Right	Peds	
06:00	17	0	5	0	0	164	13	0	1	0	0	0	2	29	0	0	231
06:15	31	0	11	0	0	160	15	0	0	0	0	0	1	67	0	0	285
06:30	21	0	9	0	1	203	18	0	0	1	0	0	1	64	0	0	318
06:45	37	1	12	0	1	154	22	0	1	0	0	0	1	99	0	0	328
Total	106	1	37	0	2	681	68	0	2	1	0	0	5	259	0	0	1162
07:00	55	0	12	0	0	175	25	0	1	0	0	0	4	98	0	0	370
07:15	61	0	15	0	0	215	29	0	0	0	0	0	4	124	0	0	448
07:30	37	0	13	0	0	183	33	0	0	0	0	0	8	133	0	0	407
07:45	40	1	9	0	1	148	21	0	1	0	1	0	3	128	2	0	355
Total	193	1	49	0	1	721	108	0	2	0	1	0	19	483	2	0	1580
08:00	22	0	7	0	0	156	19	0	0	0	0	0	8	96	0	0	308
08:15	33	0	11	0	3	139	22	0	2	0	1	0	4	89	0	0	304
08:30	39	0	13	0	1	146	26	0	1	0	2	0	10	119	1	0	358
08:45	34	0	8	0	2	153	28	0	0	0	1	0	13	121	0	0	360
Total	128	0	39	0	6	594	95	0	3	0	4	0	35	425	1	0	1330
*** BREAK ***																	
15:00	44	1	13	0	2	146	55	0	3	0	7	0	13	177	3	0	464
15:15	62	0	16	0	4	139	50	0	0	2	1	0	21	158	1	0	454
15:30	52	1	20	0	1	133	60	0	1	0	1	0	19	191	2	0	481
15:45	63	2	11	0	1	140	52	0	1	2	1	0	24	195	1	0	493
Total	221	4	60	0	8	558	217	0	5	4	10	0	77	721	7	0	1892
16:00	64	2	17	0	1	128	56	0	0	1	2	0	26	191	2	0	490
16:15	63	1	7	0	1	155	63	0	1	1	1	0	20	218	2	0	533
16:30	45	2	9	0	1	179	72	0	0	1	1	0	20	217	1	0	548
16:45	63	1	7	0	1	151	68	0	0	2	2	0	27	244	2	0	568
Total	235	6	40	0	4	613	259	0	1	5	6	0	93	870	7	0	2139
17:00	61	0	7	0	1	138	52	0	0	0	2	0	22	221	0	0	504
17:15	76	1	10	0	1	130	64	0	0	1	1	0	26	210	1	0	521
17:30	53	1	10	0	1	124	47	0	2	0	2	0	24	183	0	0	447
17:45	50	0	12	0	0	111	50	0	1	0	2	0	14	205	2	0	447
Total	240	2	39	0	3	503	213	0	3	1	7	0	86	819	3	0	1919
Grand Total	1123	14	264	0	24	3670	960	0	16	11	28	0	315	3577	20	0	10022
Apprch %	80.2	1	18.8	0	0.5	78.9	20.6	0	29.1	20	50.9	0	8.1	91.4	0.5	0	
Total %	11.2	0.1	2.6	0	0.2	36.6	9.6	0	0.2	0.1	0.3	0	3.1	35.7	0.2	0	



MINNESOTA DEPT OF TRANSPORTATION

TRAFFIC DATA COLLECTION - METRO

TH-8 at Lincoln Rd / CSAH-14
 Ref.Pt.: 011.136 LINDSTROM
 JAMAR # 631 CP
 TURN MOVEMENT COUNT

File Name : TH-8 at Lincoln Rd CSAH-14 2010
 Site Code : 00000000
 Start Date : 5/26/2010
 Page No : 2

Start Time	Lincoln Rd / CSAH-14 Southbound					TH-8 Westbound					Lincoln Rd Northbound					TH-8 Eastbound					Int. Total
	Left	Thru	Right	Peds	App. Total	Left	Thru	Right	Peds	App. Total	Left	Thru	Right	Peds	App. Total	Left	Thru	Right	Peds	App. Total	
Peak Hour Analysis From 06:00 to 08:45 - Peak 1 of 1																					
Peak Hour for Entire Intersection Begins at 07:00																					
07:00	55	0	12	0	67	0	175	25	0	200	1	0	0	0	1	4	98	0	0	102	370
07:15	61	0	15	0	76	0	215	29	0	244	0	0	0	0	0	4	124	0	0	128	448
07:30	37	0	13	0	50	0	183	33	0	216	0	0	0	0	0	8	133	0	0	141	407
07:45	40	1	9	0	50	1	148	21	0	170	1	0	1	0	2	3	128	2	0	133	355
Total Volume	193	1	49	0	243	1	721	108	0	830	2	0	1	0	3	19	483	2	0	504	1580
% App. Total	79.4	0.4	20.2	0		0.1	86.9	13	0		66.7	0	33.3	0		3.8	95.8	0.4	0		
PHF	.791	.250	.817	.000	.799	.250	.838	.818	.000	.850	.500	.000	.250	.000	.375	.594	.908	.250	.000	.894	.882

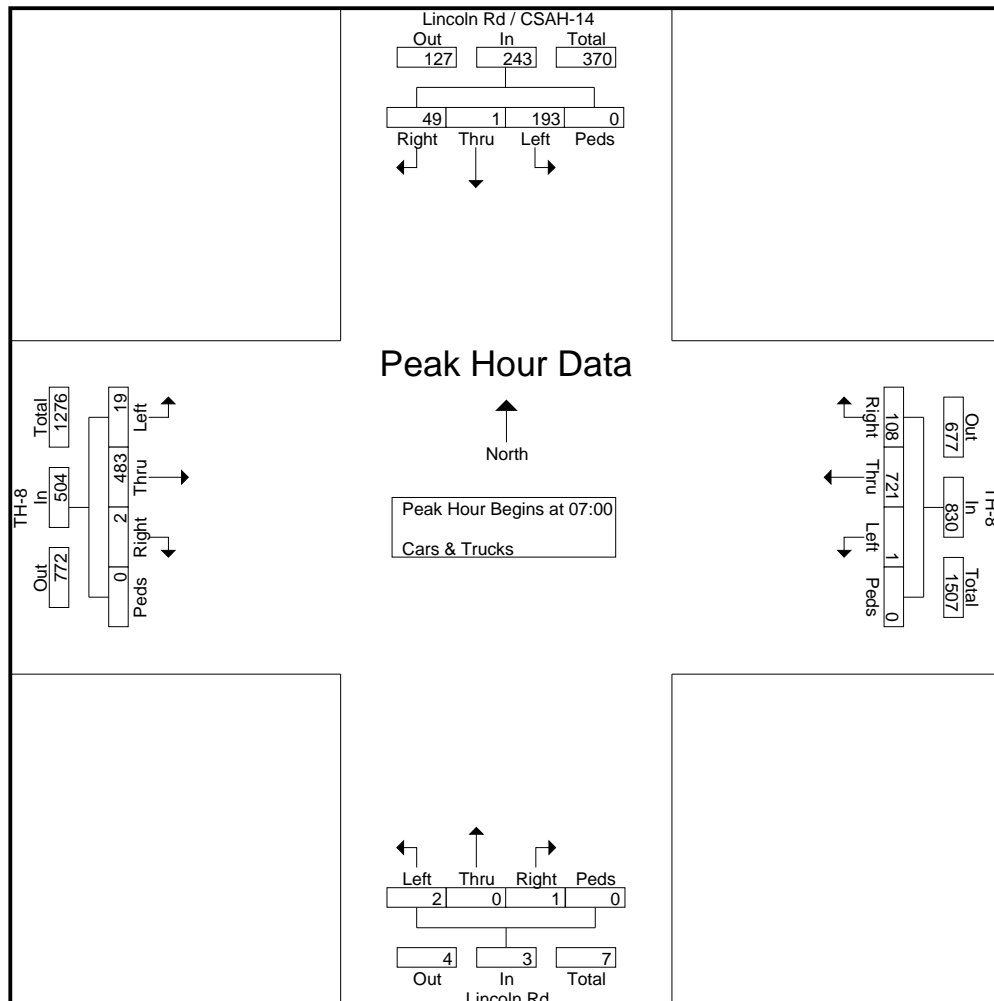



MINNESOTA DEPT OF TRANSPORTATION

TRAFFIC DATA COLLECTION - METRO

TH-8 at Lincoln Rd / CSAH-14
 Ref.Pt.: 011.136 LINDSTROM
 JAMAR # 631 CP
 TURN MOVEMENT COUNT

File Name : TH-8 at Lincoln Rd CSAH-14 2010
 Site Code : 00000000
 Start Date : 5/26/2010
 Page No : 3

Start Time	Lincoln Rd / CSAH-14 Southbound					TH-8 Westbound					Lincoln Rd Northbound					TH-8 Eastbound					Int. Total
	Left	Thru	Right	Peds	App. Total	Left	Thru	Right	Peds	App. Total	Left	Thru	Right	Peds	App. Total	Left	Thru	Right	Peds	App. Total	
16:15	63	1	7	0	71	1	155	63	0	219	1	1	1	0	3	20	218	2	0	240	533
16:30	45	2	9	0	56	1	179	72	0	252	0	1	1	0	2	20	217	1	0	238	548
16:45	63	1	7	0	71	1	151	68	0	220	0	2	2	0	4	27	244	2	0	273	568
17:00	61	0	7	0	68	1	138	52	0	191	0	0	2	0	2	22	221	0	0	243	504
Total Volume	232	4	30	0	266	4	623	255	0	882	1	4	6	0	11	89	900	5	0	994	2153
% App. Total	87.2	1.5	11.3	0		0.5	70.6	28.9	0		9.1	36.4	54.5	0		9	90.5	0.5	0		
PHF	.921	.500	.833	.000	.937	1.000	.870	.885	.000	.875	.250	.500	.750	.000	.688	.824	.922	.625	.000	.910	.948

Peak Hour Analysis From 15:00 to 17:45 - Peak 1 of 1
 Peak Hour for Entire Intersection Begins at 16:15

