



# MINNESOTA DEPT OF TRANSPORTATION

## TRAFFIC DATA COLLECTION - METRO

TH-8 at Pleasant Valley Rd / CSAH-82/26

Ref.Pt.: 014.327

JAMAR # D4-3365 EP

TURN MOVEMENT COUNT

File Name : TH-8 at Pleasant Valley Rd CSAH-26 2011

Site Code : 00000000

Start Date : 11/16/2011

Page No : 1

### Groups Printed- Cars & Trucks - local

Start Time	Pleasant Valley Rd / CSAH-82 Southbound				TH-8 Westbound				Pleasant Valley Rd / CSAH-26 Northbound				TH-8 Eastbound				Int. Total
	Left	Thru	Right	Peds	Left	Thru	Right	Peds	Left	Thru	Right	Peds	Left	Thru	Right	Peds	
06:00	0	3	1	0	7	78	0	0	4	0	1	0	1	18	15	0	128
06:15	0	3	0	0	5	85	1	0	4	0	0	0	0	22	12	0	132
06:30	0	4	0	0	3	74	1	0	2	3	0	0	2	27	16	0	132
06:45	0	9	0	0	10	85	0	0	13	1	0	0	1	27	30	0	176
Total	0	19	1	0	25	322	2	0	23	4	1	0	4	94	73	0	568
07:00	0	3	3	0	6	99	0	0	14	2	0	0	1	43	21	0	192
07:15	1	4	2	0	8	82	1	0	9	3	0	0	0	29	18	0	157
07:30	0	9	3	0	10	65	0	0	10	1	0	0	0	42	64	0	204
07:45	1	4	1	0	27	60	1	0	16	2	1	0	1	52	82	0	248
Total	2	20	9	0	51	306	2	0	49	8	1	0	2	166	185	0	801
08:00	0	3	1	0	16	62	0	0	8	3	3	0	1	39	28	0	164
08:15	0	4	1	0	8	65	0	0	5	3	1	0	1	44	25	0	157
08:30	0	3	1	0	4	69	0	0	10	1	2	0	0	48	20	0	158
08:45	1	0	1	0	4	67	0	0	10	1	0	0	3	33	21	0	141
Total	1	10	4	0	32	263	0	0	33	8	6	0	5	164	94	0	620
*** BREAK ***																	
15:00	0	3	5	0	2	60	1	0	20	4	9	0	3	102	18	0	227
15:15	0	2	4	0	2	63	0	0	33	2	5	0	1	71	14	0	197
15:30	0	0	1	0	1	63	0	0	27	5	8	0	2	66	6	0	179
15:45	0	3	3	0	4	67	0	0	24	4	9	0	1	105	9	0	229
Total	0	8	13	0	9	253	1	0	104	15	31	0	7	344	47	0	832
16:00	0	0	3	0	2	49	0	0	28	6	10	0	1	114	11	0	224
16:15	1	1	2	0	0	53	0	0	35	6	8	0	1	127	11	0	245
16:30	1	5	0	0	2	59	1	0	54	9	20	0	0	112	7	0	270
16:45	0	1	2	0	2	55	0	0	36	2	13	0	0	106	11	0	228
Total	2	7	7	0	6	216	1	0	153	23	51	0	2	459	40	0	967
17:00	2	2	0	0	0	56	0	0	34	5	4	0	0	113	13	0	229
17:15	1	1	0	0	3	59	1	0	42	1	7	0	1	97	6	0	219
17:30	0	1	0	0	1	36	1	0	24	3	1	0	0	96	15	0	178
17:45	0	2	0	0	1	51	2	0	13	5	0	0	0	74	10	0	158
Total	3	6	0	0	5	202	4	0	113	14	12	0	1	380	44	0	784
Grand Total	8	70	34	0	128	1562	10	0	475	72	102	0	21	1607	483	0	4572
Apprch %	7.1	62.5	30.4	0	7.5	91.9	0.6	0	73.2	11.1	15.7	0	1	76.1	22.9	0	
Total %	0.2	1.5	0.7	0	2.8	34.2	0.2	0	10.4	1.6	2.2	0	0.5	35.1	10.6	0	
Cars & Trucks	8	69	28	0	127	1562	10	0	475	72	102	0	10	1607	483	0	4553
% Cars & Trucks	100	98.6	82.4	0	99.2	100	100	0	100	100	100	0	47.6	100	100	0	99.6
Construction Trucks - local	0	1	6	0	1	0	0	0	0	0	0	0	11	0	0	0	19
% Construction Trucks - local	0	1.4	17.6	0	0.8	0	0	0	0	0	0	0	52.4	0	0	0	0.4



# MINNESOTA DEPT OF TRANSPORTATION

TRAFFIC DATA COLLECTION - METRO

TH-8 at Pleasant Valley Rd / CSAH-82/26  
 Ref.Pt.: 014.327  
 JAMAR # D4-3365 EP  
 TURN MOVEMENT COUNT

File Name : TH-8 at Pleasant Valley Rd CSAH-26 2011  
 Site Code : 00000000  
 Start Date : 11/16/2011  
 Page No : 2

Start Time	Pleasant Valley Rd / CSAH-82 Southbound					TH-8 Westbound					Pleasant Valley Rd / CSAH-26 Northbound					TH-8 Eastbound					Int. Total
	Left	Thru	Right	Peds	App. Total	Left	Thru	Right	Peds	App. Total	Left	Thru	Right	Peds	App. Total	Left	Thru	Right	Peds	App. Total	
Peak Hour Analysis From 06:00 to 08:45 - Peak 1 of 1																					
Peak Hour for Entire Intersection Begins at 07:00																					
07:00	0	3	3	0	6	6	99	0	0	105	14	2	0	0	16	1	43	21	0	65	192
07:15	1	4	2	0	7	8	82	1	0	91	9	3	0	0	12	0	29	18	0	47	157
07:30	0	9	3	0	12	10	65	0	0	75	10	1	0	0	11	0	42	64	0	106	204
07:45	1	4	1	0	6	27	60	1	0	88	16	2	1	0	19	1	52	82	0	135	248
Total Volume	2	20	9	0	31	51	306	2	0	359	49	8	1	0	58	2	166	185	0	353	801
% App. Total	6.5	64.5	29	0		14.2	85.2	0.6	0		84.5	13.8	1.7	0		0.6	47	52.4	0		
PHF	.500	.556	.750	.000	.646	.472	.773	.500	.000	.855	.766	.667	.250	.000	.763	.500	.798	.564	.000	.654	.807

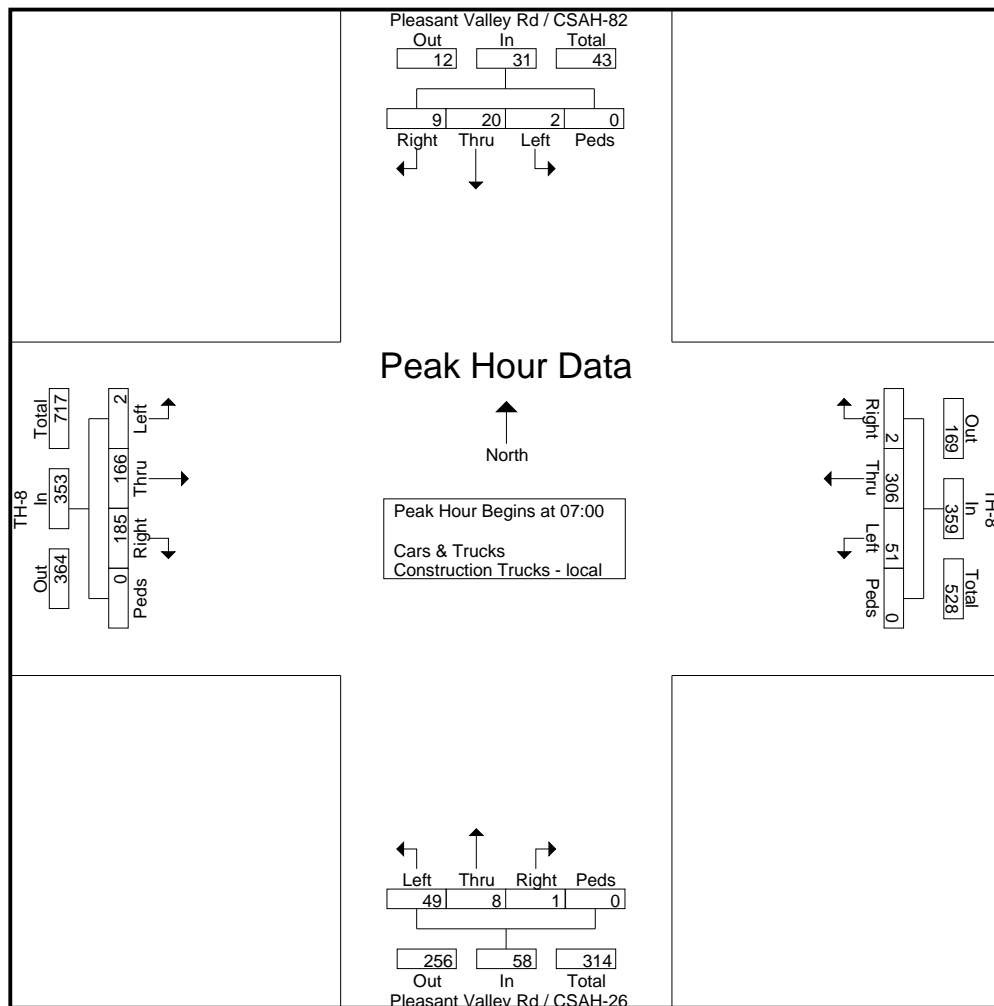



# MINNESOTA DEPT OF TRANSPORTATION

## TRAFFIC DATA COLLECTION - METRO

TH-8 at Pleasant Valley Rd / CSAH-82/26  
 Ref.Pt.: 014.327  
 JAMAR # D4-3365 EP  
 TURN MOVEMENT COUNT

File Name : TH-8 at Pleasant Valley Rd CSAH-26 2011  
 Site Code : 00000000  
 Start Date : 11/16/2011  
 Page No : 3

Start Time	Pleasant Valley Rd / CSAH-82 Southbound					TH-8 Westbound					Pleasant Valley Rd / CSAH-26 Northbound					TH-8 Eastbound					Int. Total
	Left	Thru	Right	Peds	App. Total	Left	Thru	Right	Peds	App. Total	Left	Thru	Right	Peds	App. Total	Left	Thru	Right	Peds	App. Total	
Peak Hour Analysis From 15:00 to 17:45 - Peak 1 of 1																					
Peak Hour for Entire Intersection Begins at 16:15																					
16:15	1	1	2	0	4	0	53	0	0	53	35	6	8	0	49	1	127	11	0	139	245
16:30	1	5	0	0	6	2	59	1	0	62	54	9	20	0	83	0	112	7	0	119	270
16:45	0	1	2	0	3	2	55	0	0	57	36	2	13	0	51	0	106	11	0	117	228
17:00	2	2	0	0	4	0	56	0	0	56	34	5	4	0	43	0	113	13	0	126	229
Total Volume	4	9	4	0	17	4	223	1	0	228	159	22	45	0	226	1	458	42	0	501	972
% App. Total	23.5	52.9	23.5	0		1.8	97.8	0.4	0		70.4	9.7	19.9	0		0.2	91.4	8.4	0		
PHF	.500	.450	.500	.000	.708	.500	.945	.250	.000	.919	.736	.611	.563	.000	.681	.250	.902	.808	.000	.901	.900

