



MINNESOTA DEPT OF TRANSPORTATION

TRAFFIC DATA COLLECTION - METRO

TH-95 at Grand Ave /CSAH-14 No. Branch

Ref.Pt.: 055.543

Video

TURN MOVEMENT COUNT

File Name : th-95 at grand ave csah-14 2013 24hr

Site Code :

Start Date : 11/6/2013

Page No : 1

Groups Printed- Cars +

| Start Time | Grand Ave Southbound | | | | TH-95 Westbound | | | | Grand Ave Northbound | | | | TH-95 Eastbound | | | | Int. Total |
|------------|----------------------|------|------|------|-----------------|------|------|------|----------------------|------|------|------|-----------------|------|------|------|------------|
| | Right | Thru | Left | Peds | Right | Thru | Left | Peds | Right | Thru | Left | Peds | Right | Thru | Left | Peds | |
| 00:00 | 0 | 0 | 0 | 0 | 0 | 3 | 0 | 0 | 0 | 0 | 2 | 0 | 4 | 8 | 0 | 0 | 17 |
| 00:15 | 0 | 0 | 0 | 0 | 0 | 1 | 0 | 0 | 0 | 0 | 1 | 0 | 3 | 4 | 0 | 0 | 9 |
| 00:30 | 0 | 0 | 0 | 0 | 0 | 3 | 1 | 0 | 1 | 0 | 2 | 0 | 1 | 2 | 0 | 0 | 10 |
| 00:45 | 0 | 0 | 0 | 0 | 0 | 2 | 0 | 0 | 0 | 0 | 2 | 0 | 3 | 0 | 0 | 0 | 7 |
| Total | 0 | 0 | 0 | 0 | 0 | 9 | 1 | 0 | 1 | 0 | 7 | 0 | 11 | 14 | 0 | 0 | 43 |
| 01:00 | 0 | 0 | 0 | 0 | 0 | 3 | 0 | 0 | 1 | 0 | 3 | 0 | 5 | 3 | 0 | 0 | 15 |
| 01:15 | 0 | 0 | 0 | 0 | 0 | 5 | 0 | 0 | 1 | 0 | 1 | 0 | 4 | 6 | 0 | 0 | 17 |
| 01:30 | 1 | 0 | 0 | 0 | 0 | 0 | 1 | 0 | 0 | 0 | 3 | 0 | 0 | 2 | 0 | 0 | 7 |
| 01:45 | 0 | 0 | 0 | 0 | 0 | 1 | 0 | 0 | 0 | 0 | 1 | 0 | 2 | 1 | 0 | 0 | 5 |
| Total | 1 | 0 | 0 | 0 | 0 | 9 | 1 | 0 | 2 | 0 | 8 | 0 | 11 | 12 | 0 | 0 | 44 |
| 02:00 | 0 | 0 | 0 | 0 | 0 | 0 | 1 | 0 | 1 | 0 | 6 | 0 | 3 | 2 | 0 | 0 | 13 |
| 02:15 | 0 | 0 | 0 | 0 | 0 | 0 | 0 | 0 | 0 | 0 | 0 | 0 | 0 | 2 | 0 | 0 | 2 |
| 02:30 | 0 | 0 | 0 | 0 | 0 | 4 | 0 | 0 | 0 | 0 | 2 | 0 | 1 | 1 | 0 | 0 | 8 |
| 02:45 | 0 | 0 | 0 | 0 | 0 | 0 | 0 | 0 | 0 | 0 | 0 | 0 | 3 | 3 | 0 | 0 | 6 |
| Total | 0 | 0 | 0 | 0 | 0 | 4 | 1 | 0 | 1 | 0 | 8 | 0 | 7 | 8 | 0 | 0 | 29 |
| 03:00 | 0 | 0 | 0 | 0 | 0 | 1 | 0 | 0 | 0 | 0 | 2 | 0 | 3 | 0 | 0 | 0 | 6 |
| 03:15 | 0 | 0 | 0 | 0 | 0 | 2 | 0 | 0 | 1 | 0 | 2 | 0 | 2 | 2 | 0 | 0 | 9 |
| 03:30 | 0 | 0 | 0 | 0 | 0 | 5 | 0 | 0 | 0 | 0 | 0 | 0 | 0 | 2 | 0 | 0 | 7 |
| 03:45 | 1 | 0 | 0 | 0 | 0 | 7 | 0 | 0 | 0 | 0 | 5 | 0 | 1 | 1 | 0 | 0 | 15 |
| Total | 1 | 0 | 0 | 0 | 0 | 15 | 0 | 0 | 1 | 0 | 9 | 0 | 6 | 5 | 0 | 0 | 37 |
| 04:00 | 0 | 0 | 0 | 0 | 0 | 4 | 0 | 0 | 1 | 0 | 6 | 0 | 3 | 2 | 0 | 0 | 16 |
| 04:15 | 1 | 0 | 0 | 0 | 0 | 10 | 0 | 0 | 0 | 0 | 9 | 0 | 1 | 6 | 0 | 0 | 27 |
| 04:30 | 1 | 0 | 0 | 0 | 0 | 13 | 0 | 0 | 1 | 0 | 14 | 0 | 2 | 11 | 0 | 0 | 42 |
| 04:45 | 0 | 0 | 0 | 0 | 0 | 23 | 0 | 0 | 0 | 0 | 13 | 0 | 5 | 6 | 0 | 0 | 47 |
| Total | 2 | 0 | 0 | 0 | 0 | 50 | 0 | 0 | 2 | 0 | 42 | 0 | 11 | 25 | 0 | 0 | 132 |
| 05:00 | 1 | 0 | 0 | 0 | 1 | 37 | 0 | 0 | 0 | 0 | 19 | 0 | 3 | 6 | 0 | 0 | 67 |
| 05:15 | 0 | 1 | 1 | 0 | 0 | 30 | 3 | 0 | 0 | 0 | 23 | 0 | 10 | 4 | 0 | 0 | 72 |
| 05:30 | 1 | 1 | 0 | 0 | 0 | 35 | 1 | 0 | 1 | 1 | 30 | 0 | 15 | 5 | 0 | 0 | 90 |
| 05:45 | 0 | 2 | 0 | 0 | 0 | 30 | 3 | 0 | 0 | 0 | 31 | 0 | 21 | 9 | 0 | 0 | 96 |
| Total | 2 | 4 | 1 | 0 | 1 | 132 | 7 | 0 | 1 | 1 | 103 | 0 | 49 | 24 | 0 | 0 | 325 |
| 06:00 | 1 | 3 | 0 | 0 | 0 | 36 | 4 | 0 | 2 | 0 | 28 | 0 | 18 | 16 | 1 | 0 | 109 |
| 06:15 | 2 | 4 | 0 | 0 | 0 | 33 | 2 | 0 | 4 | 0 | 42 | 0 | 38 | 18 | 2 | 0 | 145 |
| 06:30 | 0 | 1 | 0 | 0 | 0 | 39 | 4 | 0 | 2 | 1 | 61 | 0 | 43 | 18 | 1 | 0 | 170 |
| 06:45 | 0 | 7 | 0 | 0 | 0 | 42 | 16 | 0 | 1 | 2 | 44 | 0 | 96 | 12 | 0 | 0 | 220 |
| Total | 3 | 15 | 0 | 0 | 0 | 150 | 26 | 0 | 9 | 3 | 175 | 0 | 195 | 64 | 4 | 0 | 644 |
| 07:00 | 0 | 7 | 1 | 0 | 1 | 39 | 26 | 0 | 3 | 3 | 53 | 0 | 88 | 19 | 0 | 0 | 240 |
| 07:15 | 0 | 34 | 1 | 0 | 1 | 42 | 26 | 0 | 7 | 9 | 98 | 0 | 112 | 15 | 0 | 0 | 345 |
| 07:30 | 0 | 14 | 1 | 0 | 0 | 43 | 17 | 0 | 4 | 15 | 98 | 0 | 73 | 30 | 0 | 0 | 295 |
| 07:45 | 1 | 3 | 0 | 0 | 0 | 53 | 6 | 0 | 8 | 7 | 91 | 0 | 34 | 28 | 2 | 0 | 233 |
| Total | 1 | 58 | 3 | 0 | 2 | 177 | 75 | 0 | 22 | 34 | 340 | 0 | 307 | 92 | 2 | 0 | 1113 |
| 08:00 | 1 | 1 | 1 | 0 | 1 | 28 | 6 | 0 | 3 | 1 | 53 | 0 | 24 | 18 | 0 | 0 | 137 |
| 08:15 | 0 | 1 | 2 | 0 | 1 | 36 | 2 | 0 | 5 | 3 | 35 | 0 | 21 | 18 | 2 | 0 | 126 |
| 08:30 | 1 | 1 | 0 | 0 | 1 | 28 | 1 | 0 | 0 | 0 | 44 | 0 | 29 | 28 | 5 | 0 | 138 |
| 08:45 | 0 | 3 | 4 | 0 | 1 | 30 | 4 | 0 | 0 | 2 | 54 | 0 | 32 | 25 | 2 | 0 | 157 |
| Total | 2 | 6 | 7 | 0 | 4 | 122 | 13 | 0 | 8 | 6 | 186 | 0 | 106 | 89 | 9 | 0 | 558 |



MINNESOTA DEPT OF TRANSPORTATION

TRAFFIC DATA COLLECTION - METRO

TH-95 at Grand Ave /CSAH-14 No. Branch

Ref.Pt.: 055.543

Video

TURN MOVEMENT COUNT

File Name : th-95 at grand ave csah-14 2013 24hr

Site Code :

Start Date : 11/6/2013

Page No : 2

Groups Printed- Cars +

| Start Time | Grand Ave Southbound | | | | TH-95 Westbound | | | | Grand Ave Northbound | | | | TH-95 Eastbound | | | | Int. Total |
|------------|----------------------|------|------|------|-----------------|------|------|------|----------------------|------|------|------|-----------------|------|------|------|------------|
| | Right | Thru | Left | Peds | Right | Thru | Left | Peds | Right | Thru | Left | Peds | Right | Thru | Left | Peds | |
| 09:00 | 1 | 2 | 1 | 0 | 0 | 32 | 0 | 0 | 3 | 1 | 49 | 0 | 26 | 23 | 1 | 0 | 139 |
| 09:15 | 0 | 2 | 0 | 0 | 0 | 29 | 4 | 0 | 2 | 1 | 27 | 0 | 20 | 28 | 0 | 0 | 113 |
| 09:30 | 0 | 2 | 1 | 0 | 0 | 31 | 1 | 0 | 0 | 4 | 39 | 0 | 30 | 16 | 0 | 0 | 124 |
| 09:45 | 0 | 3 | 1 | 0 | 0 | 48 | 2 | 0 | 3 | 1 | 53 | 0 | 24 | 18 | 0 | 0 | 153 |
| Total | 1 | 9 | 3 | 0 | 0 | 140 | 7 | 0 | 8 | 7 | 168 | 0 | 100 | 85 | 1 | 0 | 529 |
| 10:00 | 0 | 2 | 0 | 0 | 0 | 25 | 3 | 0 | 2 | 3 | 34 | 0 | 29 | 31 | 0 | 0 | 129 |
| 10:15 | 0 | 2 | 1 | 0 | 0 | 31 | 3 | 0 | 2 | 2 | 26 | 0 | 26 | 26 | 0 | 0 | 119 |
| 10:30 | 0 | 3 | 1 | 0 | 1 | 31 | 1 | 0 | 1 | 0 | 26 | 0 | 22 | 18 | 0 | 0 | 104 |
| 10:45 | 0 | 2 | 2 | 0 | 1 | 29 | 2 | 0 | 2 | 0 | 37 | 0 | 30 | 25 | 0 | 0 | 130 |
| Total | 0 | 9 | 4 | 0 | 2 | 116 | 9 | 0 | 7 | 5 | 123 | 0 | 107 | 100 | 0 | 0 | 482 |
| 11:00 | 0 | 6 | 1 | 0 | 0 | 32 | 3 | 0 | 0 | 1 | 41 | 0 | 38 | 25 | 0 | 0 | 147 |
| 11:15 | 0 | 5 | 1 | 0 | 2 | 30 | 1 | 0 | 1 | 1 | 38 | 0 | 41 | 19 | 0 | 0 | 139 |
| 11:30 | 0 | 1 | 2 | 0 | 0 | 31 | 1 | 0 | 5 | 5 | 76 | 0 | 33 | 19 | 1 | 0 | 174 |
| 11:45 | 0 | 3 | 0 | 0 | 0 | 22 | 3 | 0 | 3 | 2 | 36 | 0 | 37 | 21 | 0 | 0 | 127 |
| Total | 0 | 15 | 4 | 0 | 2 | 115 | 8 | 0 | 9 | 9 | 191 | 0 | 149 | 84 | 1 | 0 | 587 |
| 12:00 | 0 | 3 | 1 | 0 | 0 | 31 | 2 | 0 | 8 | 3 | 34 | 0 | 51 | 28 | 0 | 0 | 161 |
| 12:15 | 1 | 2 | 2 | 0 | 0 | 32 | 2 | 0 | 2 | 2 | 80 | 0 | 39 | 31 | 1 | 0 | 194 |
| 12:30 | 0 | 3 | 0 | 0 | 0 | 25 | 4 | 0 | 1 | 3 | 34 | 0 | 41 | 26 | 0 | 0 | 137 |
| 12:45 | 2 | 2 | 0 | 0 | 0 | 34 | 1 | 0 | 5 | 1 | 41 | 0 | 21 | 43 | 0 | 0 | 150 |
| Total | 3 | 10 | 3 | 0 | 0 | 122 | 9 | 0 | 16 | 9 | 189 | 0 | 152 | 128 | 1 | 0 | 642 |
| 13:00 | 1 | 5 | 2 | 0 | 0 | 20 | 0 | 0 | 1 | 0 | 33 | 0 | 26 | 32 | 0 | 0 | 120 |
| 13:15 | 0 | 1 | 3 | 0 | 0 | 25 | 2 | 0 | 1 | 0 | 39 | 0 | 37 | 34 | 1 | 0 | 143 |
| 13:30 | 1 | 1 | 2 | 0 | 0 | 24 | 2 | 0 | 1 | 1 | 39 | 0 | 32 | 34 | 0 | 0 | 137 |
| 13:45 | 0 | 3 | 1 | 0 | 1 | 31 | 2 | 0 | 0 | 3 | 49 | 0 | 36 | 31 | 0 | 0 | 157 |
| Total | 2 | 10 | 8 | 0 | 1 | 100 | 6 | 0 | 3 | 4 | 160 | 0 | 131 | 131 | 1 | 0 | 557 |
| 14:00 | 0 | 1 | 3 | 0 | 1 | 21 | 0 | 0 | 2 | 0 | 41 | 0 | 39 | 34 | 0 | 0 | 142 |
| 14:15 | 0 | 2 | 1 | 0 | 0 | 31 | 3 | 0 | 3 | 3 | 38 | 0 | 28 | 44 | 0 | 0 | 153 |
| 14:30 | 2 | 7 | 1 | 0 | 1 | 25 | 0 | 0 | 3 | 1 | 42 | 0 | 39 | 28 | 0 | 0 | 149 |
| 14:45 | 0 | 6 | 1 | 0 | 0 | 25 | 1 | 0 | 4 | 2 | 43 | 0 | 49 | 38 | 2 | 0 | 171 |
| Total | 2 | 16 | 6 | 0 | 2 | 102 | 4 | 0 | 12 | 6 | 164 | 0 | 155 | 144 | 2 | 0 | 615 |
| 15:00 | 1 | 7 | 6 | 0 | 0 | 25 | 4 | 0 | 5 | 3 | 44 | 0 | 44 | 30 | 0 | 0 | 169 |
| 15:15 | 0 | 7 | 7 | 0 | 1 | 36 | 2 | 0 | 1 | 2 | 40 | 0 | 80 | 39 | 1 | 0 | 216 |
| 15:30 | 2 | 10 | 5 | 3 | 2 | 28 | 12 | 4 | 16 | 16 | 96 | 0 | 69 | 42 | 0 | 0 | 305 |
| 15:45 | 3 | 9 | 1 | 14 | 1 | 47 | 5 | 21 | 17 | 27 | 102 | 0 | 54 | 51 | 2 | 0 | 354 |
| Total | 6 | 33 | 19 | 17 | 4 | 136 | 23 | 25 | 39 | 48 | 282 | 0 | 247 | 162 | 3 | 0 | 1044 |
| 16:00 | 0 | 6 | 4 | 0 | 1 | 34 | 2 | 0 | 16 | 6 | 97 | 0 | 63 | 48 | 3 | 0 | 280 |
| 16:15 | 2 | 5 | 1 | 0 | 0 | 35 | 7 | 2 | 7 | 9 | 94 | 0 | 49 | 51 | 2 | 0 | 264 |
| 16:30 | 2 | 4 | 6 | 2 | 1 | 39 | 5 | 0 | 7 | 16 | 67 | 0 | 63 | 56 | 0 | 0 | 268 |
| 16:45 | 0 | 7 | 4 | 1 | 2 | 30 | 5 | 1 | 7 | 7 | 80 | 0 | 74 | 74 | 3 | 0 | 295 |
| Total | 4 | 22 | 15 | 3 | 4 | 138 | 19 | 3 | 37 | 38 | 338 | 0 | 249 | 229 | 8 | 0 | 1107 |
| 17:00 | 0 | 3 | 10 | 1 | 1 | 41 | 10 | 0 | 10 | 8 | 78 | 1 | 81 | 76 | 1 | 0 | 321 |
| 17:15 | 1 | 5 | 2 | 1 | 1 | 39 | 2 | 0 | 4 | 3 | 81 | 0 | 78 | 37 | 0 | 0 | 254 |
| 17:30 | 1 | 4 | 4 | 0 | 0 | 32 | 8 | 1 | 8 | 5 | 65 | 0 | 66 | 47 | 0 | 0 | 241 |
| 17:45 | 0 | 3 | 4 | 0 | 0 | 40 | 5 | 0 | 6 | 2 | 50 | 0 | 54 | 41 | 1 | 0 | 206 |
| Total | 2 | 15 | 20 | 2 | 2 | 152 | 25 | 1 | 28 | 18 | 274 | 1 | 279 | 201 | 2 | 0 | 1022 |
| 18:00 | 0 | 7 | 7 | 0 | 0 | 37 | 3 | 0 | 5 | 3 | 52 | 0 | 64 | 57 | 2 | 0 | 237 |



MINNESOTA DEPT OF TRANSPORTATION

TRAFFIC DATA COLLECTION - METRO

TH-95 at Grand Ave /CSAH-14 No. Branch

Ref.Pt.: 055.543

Video

TURN MOVEMENT COUNT

File Name : th-95 at grand ave csah-14 2013 24hr

Site Code :

Start Date : 11/6/2013

Page No : 3

Groups Printed- Cars +

| Start Time | Grand Ave Southbound | | | | TH-95 Westbound | | | | Grand Ave Northbound | | | | TH-95 Eastbound | | | | Int. Total |
|-------------|----------------------|------|------|------|-----------------|------|------|------|----------------------|------|------|------|-----------------|------|------|------|------------|
| | Right | Thru | Left | Peds | Right | Thru | Left | Peds | Right | Thru | Left | Peds | Right | Thru | Left | Peds | |
| 18:15 | 0 | 7 | 2 | 0 | 2 | 24 | 6 | 0 | 5 | 3 | 56 | 0 | 73 | 34 | 0 | 0 | 212 |
| 18:30 | 0 | 4 | 2 | 0 | 0 | 19 | 5 | 0 | 3 | 3 | 54 | 0 | 43 | 32 | 1 | 0 | 166 |
| 18:45 | 0 | 4 | 1 | 0 | 0 | 21 | 2 | 0 | 4 | 0 | 39 | 0 | 39 | 28 | 0 | 0 | 138 |
| Total | 0 | 22 | 12 | 0 | 2 | 101 | 16 | 0 | 17 | 9 | 201 | 0 | 219 | 151 | 3 | 0 | 753 |
| 19:00 | 0 | 1 | 5 | 0 | 0 | 20 | 2 | 0 | 2 | 3 | 17 | 0 | 29 | 28 | 2 | 0 | 109 |
| 19:15 | 0 | 2 | 1 | 0 | 0 | 5 | 1 | 0 | 4 | 1 | 16 | 0 | 27 | 26 | 0 | 0 | 83 |
| 19:30 | 0 | 1 | 0 | 0 | 0 | 15 | 0 | 0 | 4 | 1 | 19 | 0 | 31 | 23 | 1 | 0 | 95 |
| 19:45 | 0 | 3 | 1 | 0 | 1 | 7 | 5 | 0 | 2 | 1 | 32 | 0 | 30 | 16 | 0 | 0 | 98 |
| Total | 0 | 7 | 7 | 0 | 1 | 47 | 8 | 0 | 12 | 6 | 84 | 0 | 117 | 93 | 3 | 0 | 385 |
| 20:00 | 1 | 0 | 1 | 0 | 0 | 13 | 3 | 0 | 9 | 4 | 49 | 0 | 28 | 19 | 0 | 0 | 127 |
| 20:15 | 0 | 3 | 2 | 0 | 0 | 14 | 2 | 0 | 5 | 0 | 34 | 0 | 35 | 34 | 0 | 0 | 129 |
| 20:30 | 0 | 1 | 1 | 0 | 0 | 18 | 1 | 0 | 4 | 0 | 24 | 0 | 21 | 21 | 0 | 0 | 91 |
| 20:45 | 0 | 0 | 0 | 0 | 0 | 7 | 1 | 0 | 5 | 1 | 13 | 0 | 15 | 20 | 0 | 0 | 62 |
| Total | 1 | 4 | 4 | 0 | 0 | 52 | 7 | 0 | 23 | 5 | 120 | 0 | 99 | 94 | 0 | 0 | 409 |
| 21:00 | 1 | 0 | 2 | 0 | 0 | 11 | 3 | 0 | 1 | 0 | 10 | 0 | 23 | 17 | 1 | 0 | 69 |
| 21:15 | 0 | 0 | 0 | 0 | 1 | 11 | 0 | 0 | 0 | 0 | 12 | 0 | 18 | 16 | 0 | 0 | 58 |
| 21:30 | 0 | 0 | 0 | 0 | 0 | 8 | 0 | 0 | 0 | 0 | 6 | 0 | 21 | 6 | 0 | 0 | 41 |
| 21:45 | 0 | 0 | 0 | 0 | 0 | 8 | 2 | 0 | 1 | 0 | 11 | 0 | 9 | 13 | 0 | 0 | 44 |
| Total | 1 | 0 | 2 | 0 | 1 | 38 | 5 | 0 | 2 | 0 | 39 | 0 | 71 | 52 | 1 | 0 | 212 |
| 22:00 | 0 | 0 | 0 | 0 | 0 | 4 | 1 | 0 | 0 | 0 | 6 | 0 | 23 | 8 | 0 | 0 | 42 |
| 22:15 | 0 | 0 | 0 | 0 | 0 | 10 | 0 | 0 | 1 | 1 | 9 | 0 | 10 | 8 | 0 | 0 | 39 |
| 22:30 | 0 | 0 | 1 | 0 | 0 | 6 | 1 | 0 | 1 | 0 | 4 | 0 | 5 | 4 | 0 | 0 | 22 |
| 22:45 | 0 | 0 | 0 | 0 | 0 | 5 | 1 | 0 | 2 | 0 | 6 | 0 | 9 | 9 | 0 | 0 | 32 |
| Total | 0 | 0 | 1 | 0 | 0 | 25 | 3 | 0 | 4 | 1 | 25 | 0 | 47 | 29 | 0 | 0 | 135 |
| 23:00 | 0 | 0 | 0 | 0 | 0 | 6 | 0 | 0 | 0 | 0 | 6 | 0 | 6 | 8 | 0 | 0 | 26 |
| 23:15 | 0 | 0 | 0 | 0 | 0 | 4 | 0 | 0 | 0 | 1 | 5 | 0 | 9 | 6 | 0 | 0 | 25 |
| 23:30 | 0 | 1 | 0 | 0 | 0 | 3 | 0 | 0 | 0 | 0 | 2 | 0 | 2 | 8 | 0 | 0 | 16 |
| 23:45 | 0 | 0 | 0 | 0 | 0 | 2 | 0 | 0 | 0 | 0 | 3 | 0 | 3 | 5 | 0 | 0 | 13 |
| Total | 0 | 1 | 0 | 0 | 0 | 15 | 0 | 0 | 0 | 1 | 16 | 0 | 20 | 27 | 0 | 0 | 80 |
| Grand Total | 34 | 256 | 119 | 22 | 28 | 2067 | 273 | 29 | 264 | 210 | 3252 | 1 | 2845 | 2043 | 41 | 0 | 11484 |
| Apprch % | 7.9 | 59.4 | 27.6 | 5.1 | 1.2 | 86.2 | 11.4 | 1.2 | 7.1 | 5.6 | 87.3 | 0 | 57.7 | 41.4 | 0.8 | 0 | |
| Total % | 0.3 | 2.2 | 1 | 0.2 | 0.2 | 18 | 2.4 | 0.3 | 2.3 | 1.8 | 28.3 | 0 | 24.8 | 17.8 | 0.4 | 0 | |



MINNESOTA DEPT OF TRANSPORTATION

TRAFFIC DATA COLLECTION - METRO

TH-95 at Grand Ave /CSAH-14 No. Branch
 Ref.Pt.: 055.543
 Video
 TURN MOVEMENT COUNT

File Name : th-95 at grand ave csah-14 2013 24hr
 Site Code :
 Start Date : 11/6/2013
 Page No : 4

| Start Time | Grand Ave Southbound | | | | | TH-95 Westbound | | | | | Grand Ave Northbound | | | | | TH-95 Eastbound | | | | | Int. Total |
|--|----------------------|------|------|------|------------|-----------------|------|------|------|------------|----------------------|------|------|------|------------|-----------------|------|------|------|------------|------------|
| | Right | Thru | Left | Peds | App. Total | Right | Thru | Left | Peds | App. Total | Right | Thru | Left | Peds | App. Total | Right | Thru | Left | Peds | App. Total | |
| Peak Hour Analysis From 00:00 to 11:45 - Peak 1 of 1 | | | | | | | | | | | | | | | | | | | | | |
| Peak Hour for Entire Intersection Begins at 07:00 | | | | | | | | | | | | | | | | | | | | | |
| 07:00 | 0 | 7 | 1 | 0 | 8 | 1 | 39 | 26 | 0 | 66 | 3 | 3 | 53 | 0 | 59 | 88 | 19 | 0 | 0 | 107 | 240 |
| 07:15 | 0 | 34 | 1 | 0 | 35 | 1 | 42 | 26 | 0 | 69 | 7 | 9 | 98 | 0 | 114 | 112 | 15 | 0 | 0 | 127 | 345 |
| 07:30 | 0 | 14 | 1 | 0 | 15 | 0 | 43 | 17 | 0 | 60 | 4 | 15 | 98 | 0 | 117 | 73 | 30 | 0 | 0 | 103 | 295 |
| 07:45 | 1 | 3 | 0 | 0 | 4 | 0 | 53 | 6 | 0 | 59 | 8 | 7 | 91 | 0 | 106 | 34 | 28 | 2 | 0 | 64 | 233 |
| Total Volume | 1 | 58 | 3 | 0 | 62 | 2 | 177 | 75 | 0 | 254 | 22 | 34 | 340 | 0 | 396 | 307 | 92 | 2 | 0 | 401 | 1113 |
| % App. Total | 1.6 | 93.5 | 4.8 | 0 | | 0.8 | 69.7 | 29.5 | 0 | | 5.6 | 8.6 | 85.9 | 0 | | 76.6 | 22.9 | 0.5 | 0 | | |
| PHF | .250 | .426 | .750 | .000 | .443 | .500 | .835 | .721 | .000 | .920 | .688 | .567 | .867 | .000 | .846 | .685 | .767 | .250 | .000 | .789 | .807 |

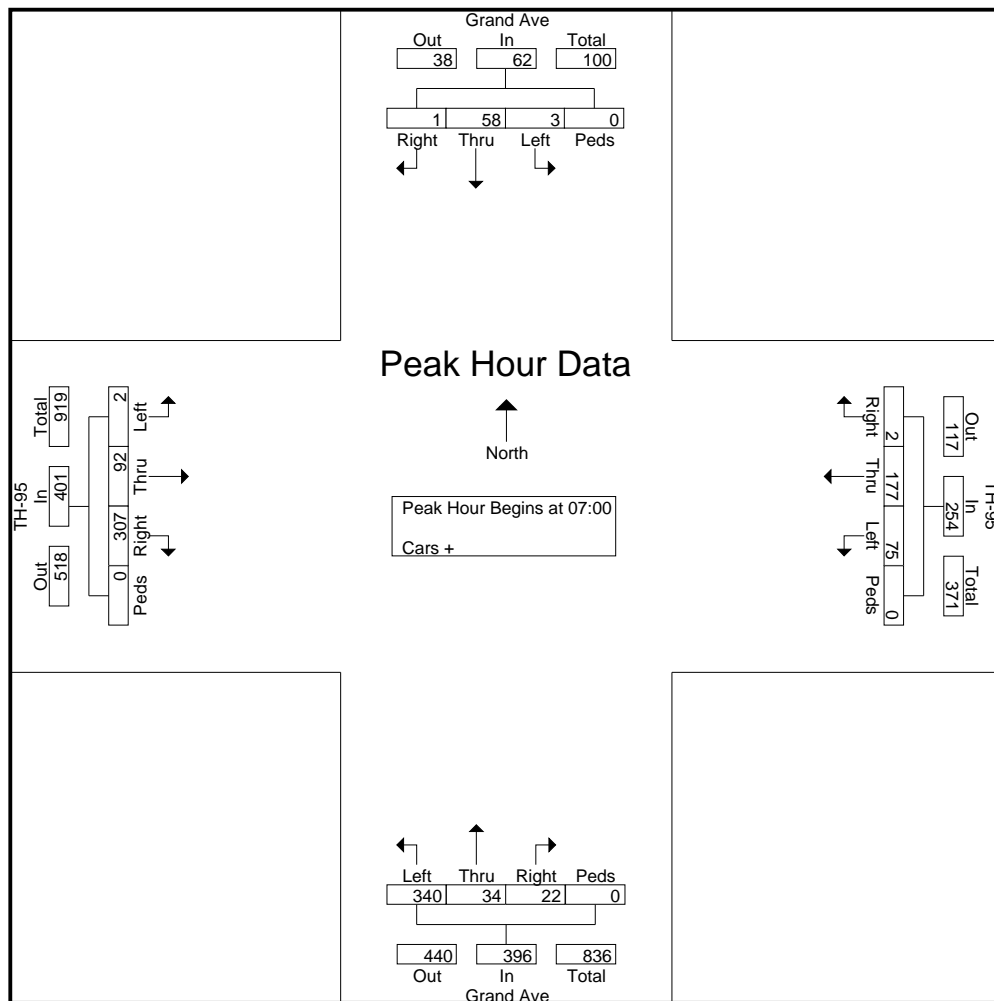



MINNESOTA DEPT OF TRANSPORTATION

TRAFFIC DATA COLLECTION - METRO

TH-95 at Grand Ave /CSAH-14 No. Branch
 Ref.Pt.: 055.543
 Video
 TURN MOVEMENT COUNT

File Name : th-95 at grand ave csah-14 2013 24hr
 Site Code :
 Start Date : 11/6/2013
 Page No : 5

| Start Time | Grand Ave Southbound | | | | | TH-95 Westbound | | | | | Grand Ave Northbound | | | | | TH-95 Eastbound | | | | | Int. Total |
|--------------|----------------------|------|------|------|------------|-----------------|------|------|------|------------|----------------------|------|------|------|------------|-----------------|------|------|------|------------|------------|
| | Right | Thru | Left | Peds | App. Total | Right | Thru | Left | Peds | App. Total | Right | Thru | Left | Peds | App. Total | Right | Thru | Left | Peds | App. Total | |
| 15:30 | 2 | 10 | 5 | 3 | 20 | 2 | 28 | 12 | 4 | 46 | 16 | 16 | 96 | 0 | 128 | 69 | 42 | 0 | 0 | 111 | 305 |
| 15:45 | 3 | 9 | 1 | 14 | 27 | 1 | 47 | 5 | 21 | 74 | 17 | 27 | 102 | 0 | 146 | 54 | 51 | 2 | 0 | 107 | 354 |
| 16:00 | 0 | 6 | 4 | 0 | 10 | 1 | 34 | 2 | 0 | 37 | 16 | 6 | 97 | 0 | 119 | 63 | 48 | 3 | 0 | 114 | 280 |
| 16:15 | 2 | 5 | 1 | 0 | 8 | 0 | 35 | 7 | 2 | 44 | 7 | 9 | 94 | 0 | 110 | 49 | 51 | 2 | 0 | 102 | 264 |
| Total Volume | 7 | 30 | 11 | 17 | 65 | 4 | 144 | 26 | 27 | 201 | 56 | 58 | 389 | 0 | 503 | 235 | 192 | 7 | 0 | 434 | 1203 |
| % App. Total | 10.8 | 46.2 | 16.9 | 26.2 | | 2 | 71.6 | 12.9 | 13.4 | | 11.1 | 11.5 | 77.3 | 0 | | 54.1 | 44.2 | 1.6 | 0 | | |
| PHF | .583 | .750 | .550 | .304 | .602 | .500 | .766 | .542 | .321 | .679 | .824 | .537 | .953 | .000 | .861 | .851 | .941 | .583 | .000 | .952 | .850 |

Peak Hour Analysis From 12:00 to 23:45 - Peak 1 of 1
 Peak Hour for Entire Intersection Begins at 15:30

